



FreeZone®

Freeze Dry Systems and Accessories



*Protecting your
laboratory environment*

LABCONCO®



FreeZone® Freeze Dry Systems

AN OVERVIEW

Table of Contents:

Overview	1
Selection Guide	4
FreeZone Freeze Dry Systems	
1 Liter Benchtop	6
2.5 Liter Benchtop	8
2.5 Liter Cascade Benchtop	10
2.5 Liter Cascade Console	12
4.5 Liter Benchtop	14
4.5 Liter Console	16
6 Liter Benchtop	18
6, 12 & 18 Liter Console	20
6 & 12 Liter Cascade Console	26
Dry Ice Freeze Dry System	29
FreeZone Triad Cascade Freeze Dry Systems	30
FreeZone Stoppering Tray Dryers	34
FreeZone Bulk Tray Dryers	37
FreeZone Triad, Stoppering Tray Dryers & Bulk Tray Dryers Accessories	39
Drying Accessories	40
Secondary Traps	43
Rotary Vane Vacuum Pumps & Accessories	44
FreeZone Benchtop Shell Freezers	47
Fast-Freeze® Flasks	48
Lyph-Lock® Flasks	49
Serum Bottles & Vials	50
Ampules & Miscellaneous Accessories	51

LABCONCO has been designing and manufacturing laboratory freeze drying equipment since 1974. Since the beginning, Labconco has strived to incorporate features that enhance environmental safety, ease-of-use and durability.

ENVIRONMENTAL SAFETY. *All refrigeration systems found in FreeZone Freeze Dry Systems, FreeZone Plus Cascade Freeze Dry Systems and FreeZone Stoppering Tray Dryers use environmentally-friendly CFC-free refrigerants.*

EASE OF USE. *FreeZone Freeze Dry Systems were designed to provide simplicity of use and convenience.*

- With automatic start up, pressing one button initiates collector refrigeration and vacuum. Vacuum pull down is delayed to allow sufficient time for the collector to cool ensuring that moisture is trapped by the collector to protect the pump from contamination.
- Lighted “wave” graphs, found on all models except FreeZone 1 Liter and Triad Systems, are visible from a distance, display amber then green, to indicate when temperature and vacuum levels are right for adding samples.



FreeZone Freeze Dry Systems in console models are available in 2.5, 4.5, 6, 12 and 18 liter collector capacities.





FreeZone® Freeze Dry Systems

A N O V E R V I E W



FreeZone 1 Liter Benchtop Freeze Dry Systems offer an economical solution for processing light sample loads or dedicated use by one researcher.

- The LCD provides easy-to-read digital readouts of vacuum in mBar, Pa or Torr and temperature in ° F or ° C. It also displays service information such as total number of hours of refrigeration and vacuum pump operation and total number of hours since the refrigeration and vacuum pump were serviced.
- The vacuum control valve, found on all models except FreeZone 1 Liter Systems, helps to speed evaporation of solvent samples by maintaining the vacuum level.
- The audible/visual alarm alerts the user to abnormal system events. Alarm messages are displayed on the LCD.
- The upright collector chamber makes defrosting easy. Some models include a built-in hot gas defrost that melts the collected ice. When the defrost function is selected, hot gas from the compressor is circulated through the collector coil. The defrost feature automatically shuts off when the refrigerant leaving the collector coil reaches +65° C (+149° F). All models may be manually defrosted by pouring water into the upright chamber to melt the collected ice. A collector drain hose allows convenient emptying of the melted ice.

* Teflon® is a registered trademark of E.I. duPont de Nemours

- The rear-mounted RS-232 port, found on all models except FreeZone 1 Liter Systems, simplifies connection to a personal computer for operation verification. The time between data transmissions may be set to occur at 10, 30, 60, 300 or 600 second intervals.

DURABILITY. FreeZone Systems have several features designed to protect the system and vacuum pump.

- The patented moisture sensor, found on all models except FreeZone 1 Liter Systems, protects the vacuum pump by preventing refrigeration or vacuum start-up when moisture is detected in the collector chamber.
- The vacuum break valve, found on all models except the FreeZone 1 Liter Systems, protects the system from oil back-streaming during power outages.
- Models are available that include a Teflon*-coated collector chamber and coil for processes involving corrosive compounds.
- The purge valve, available on FreeZone 6, 12 and 18 Liter Console Systems, allows the vacuum pump to be run after freeze drying is complete so that contaminants may be purged from the oil.



FreeZone Plus 2.5 Liter Cascade Freeze Dry Systems reach -84° C for processing samples with low eutectic points. Dual refrigeration cascade models also come in 6 and 12 liter collector capacities.



FreeZone® Freeze Dry Systems

AN OVERVIEW



Left: A built-in shell freezer may be ordered with selected models of FreeZone 6 Liter Freeze Dry Systems.

Right: A built-in mini vacuum drying chamber holds small samples and heats to +60° C (+140° F). The drying chamber may be ordered with selected models of FreeZone 6, 12 and 18 Liter Freeze Dry Systems.

Digital Control Panel Displays System Status

FreeZone® 1 Liter Freeze Dry Systems



MENU switch. Changes the display from operating system parameters to set-up parameters.

SELECT switch. Press to select between manual or automatic vacuum pump start-up, desired vacuum or temperature unit of measure.

VACUUM MANUAL ON/OFF switch. Press to start the vacuum pump manually or to stop the vacuum pump when operating in either the auto or manual start-up mode.

LCD. Displays system set-up and operating parameters. The user may configure the display to show vacuum in mBar, Pa or Torr and temperature in ° F or ° C. Other displays include: total duration of refrigeration operation, total duration since the refrigeration system was last serviced, total duration of vacuum operation and total duration since the vacuum pump was last serviced (in hours).



FreeZone® Freeze Dry Systems

AN OVERVIEW

FreeZone® 2.5–18 Liter Freeze Dry Systems

DEFROST switch with LED indicator light. Controls the hot gas chamber defrost function found on all FreeZone 6, 12 and 18 Liter Console Systems.

VACUUM switch with LED indicator light. Starts or stops the vacuum pump.

PURGE switch with LED indicator light. Controls the optional purge valve available on FreeZone 6, 12 and 18 Liter Console Systems. The green LED illuminates when the purge valve is closed, isolating the pump from the collector chamber.

MENU switch. Press to change screen display.

SELECT switch. Press to select desired vacuum or temperature unit of measure or set-up parameters.

TEMPERATURE GRAPH DISPLAY. Provides at-a-glance monitoring of the collector temperature. The highest LED illuminates amber to indicate that the temperature is warmer than +10° C. The indicators sequence down when the temperature reaches +10, 0, -10, -20, -30 and -40° C. When the collector temperature reaches -40° C, the lowest LED illuminates green, indicating temperature is right to add samples.

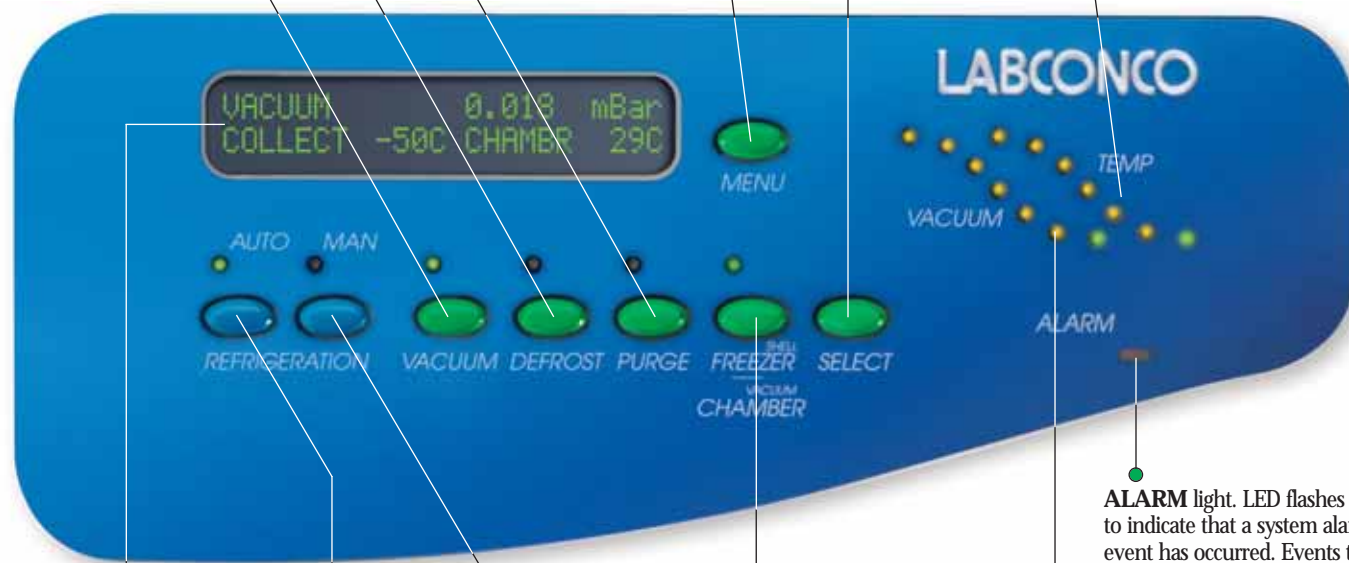

LCD. Displays system set-up and operating parameters and alarm messages. The user may configure the display to show vacuum in mBar, Pa or Torr and temperature in ° F or ° C. Other displays include: total duration of refrigeration operation and total duration since the refrigeration system was last serviced (in hours); total duration of vacuum operation and total duration since the vacuum pump was last serviced (in hours); time between RS-232 transmissions (10, 30, 60, 300 or 600 second intervals); and alarm messages: power failure, improper line voltage supply, collector temperature rise above -40° C, service vacuum pump (after 1000 hours of vacuum use) and moisture in collector.

MANUAL refrigeration switch with LED indicator light. Press to start the refrigeration only.

AUTO mode switch with LED indicator light. Controls refrigeration and the automatic mode process. In the automatic mode, the system activates the vacuum pump when the collector temperature reaches -40° C.

SHELL FREEZER switch with LED indicator light. Controls the optional shell freezer rollers and refrigeration module available on FreeZone 6 Liter Console Freeze Dry Systems.





VACUUM CHAMBER switch with LED indicator light. Controls the optional mini vacuum drying chamber available on FreeZone 6, 12 and 18 Liter Console Freeze Dry Systems.

ALARM light. LED flashes red to indicate that a system alarm event has occurred. Events that trigger the audible/visual alarm are: power failure, improper line voltage supply, collector temperature rise above -40° C, service vacuum pump (after 1000 hours of vacuum use), and moisture in collector. Pressing the Menu Switch displays the alarm message on the LCD.

VACUUM GRAPH DISPLAY. Provides at-a-glance monitoring of relative system vacuum level. The highest LED illuminates amber to indicate that the vacuum level is above 2.0 mBar. The indicators sequence down when the vacuum level reaches 2.0, 1.0, 0.8, 0.6, 0.45 and 0.12 mBar. When the vacuum level is between 0.45 and 0.12, the lowest LED flashes green. Below 0.12 mBar, the lowest LED illuminates green steadily, indicating samples may be attached to the freeze dry system.

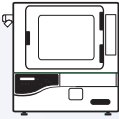

FreeZone® Freeze Dry Systems Selection Guide

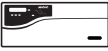
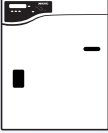
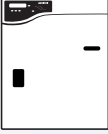
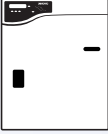
	System Capacity	Style	Application Requirements and User Preferences	Collector/ Refrigeration <i>Cools collector to -50° C (-58° F)</i> <i>Optional Teflon-coated collector available</i>	Cascade Collector/ Refrigeration <i>Cools collector to -84° C (-119° F)</i> <i>For samples with low eutectic points</i> <i>Optional Teflon-coated collector available on some models</i>
	1 Liter <i>See pages 6-7</i>	Benchtop	<ul style="list-style-type: none"> • Light sample loads • Limited floor space • Economical 	<ul style="list-style-type: none"> • 1/4 hp refrigeration system • Removes 1 liter of water in 24 hours 	
	2.5 Liters <i>See pages 8-11</i>	Benchtop	<ul style="list-style-type: none"> • Light sample loads • Limited floor space 	<ul style="list-style-type: none"> • 1/4 hp refrigeration system • Removes 2 liters of water in 24 hours 	<ul style="list-style-type: none"> • Two refrigeration systems, one 1/4 hp and one 1/3 hp • Removes 1.8 liters of water in 24 hours
	2.5 Liters <i>See pages 12-13</i>	Console	<ul style="list-style-type: none"> • Light sample loads • Low eutectic point samples 		<ul style="list-style-type: none"> • Two refrigeration systems, one 1/4 hp and one 1/3 hp • Removes 1.8 liters of water in 24 hours
	2.5 Liters <i>See pages 30-33</i>	Benchtop Triad™	<ul style="list-style-type: none"> • Light sample loads • Low eutectic point samples • Stoppers samples in bottles or vials under vacuum 		<ul style="list-style-type: none"> • Two 1/3 hp refrigeration systems • Removes 1.84 liters of water in 24 hours
	4.5 Liters <i>See pages 14-15</i>	Benchtop	<ul style="list-style-type: none"> • Light to moderate sample loads • Limited floor space 	<ul style="list-style-type: none"> • 1/3 hp refrigeration system • Removes over 2 liters of water in 24 hours 	
	4.5 Liters <i>See pages 16-17</i>	Console	<ul style="list-style-type: none"> • Light to moderate sample loads 	<ul style="list-style-type: none"> • 1/3 hp refrigeration system • Removes over 2 liters of water in 24 hours 	
	6 Liters <i>See pages 18-19</i>	Benchtop	<ul style="list-style-type: none"> • Moderate sample loads • Limited floor space • Available with Stoppering Tray Dryer 	<ul style="list-style-type: none"> • 3/4 hp refrigeration system • Removes over 4 liters of water in 24 hours 	
	6 Liters <i>See pages 20-21, 24</i>	Console	<ul style="list-style-type: none"> • Moderate sample loads • Broadest range of options • Available with Stoppering Tray Dryer 	<ul style="list-style-type: none"> • 3/4 hp refrigeration system • Removes 4 liters of water in 24 hours 	<ul style="list-style-type: none"> • Two 1/3 hp refrigeration systems • Removes over 2 liters of water in 24 hours
	12 Liters <i>See pages 20, 22, 25</i>	Console	<ul style="list-style-type: none"> • Sample loads of varying volumes • Available with Stoppering Tray Dryer 	<ul style="list-style-type: none"> • 1 hp refrigeration system • Removes 8 liters of water in 24 hours 	<ul style="list-style-type: none"> • Two 3/4 hp refrigeration systems • Removes up to 4 liters of water in 24 hours
	18 Liters <i>See pages 20, 23, 25</i>	Console	<ul style="list-style-type: none"> • Large volumes of material or numerous sample batches 	<ul style="list-style-type: none"> • 1-1/2 hp refrigeration system • Removes 10 liters of water in 24 hours 	



FreeZone® Freeze Dry Systems

O P T I O N S						
Purge Valve	Built-in Mini Vacuum Drying Chamber	Built-in Shell Freezer	Drying Accessory	Vacuum Pump	Glassware	
<i>Allows contaminants to be purged from the vacuum pump</i>	<i>Holds small samples in bulk or in small containers May be used independently or with top-mounted drying accessory</i>	<i>Pre-freezes by rotating flasks in low temperature heat transfer solution</i>	<i>Tray Dryers, Drying Chambers and Manifolds that accommodate samples in containers or in bulk</i>	<i>See pages 44-46</i>	<i>See pages 48-51</i>	
			<ul style="list-style-type: none"> • REQUIRED— See drying accessories on pages 40-42. 	<ul style="list-style-type: none"> • REQUIRED— 86 liters/minute or larger displacement 	<ul style="list-style-type: none"> • REQUIRED— unless bulk drying 	
			<ul style="list-style-type: none"> • REQUIRED— See drying accessories on pages 40-42. 	<ul style="list-style-type: none"> • REQUIRED— 86 liters/minute or larger displacement 	<ul style="list-style-type: none"> • REQUIRED— unless bulk drying 	
			<ul style="list-style-type: none"> • REQUIRED— See drying accessories on pages 40-42. 	<ul style="list-style-type: none"> • REQUIRED— 86 liters/minute or larger displacement 	<ul style="list-style-type: none"> • REQUIRED— unless bulk drying 	
			<ul style="list-style-type: none"> • Permanently installed • One stoppering shelf • 4 ports 	<ul style="list-style-type: none"> • REQUIRED— 144 liters/minute or larger displacement 	<ul style="list-style-type: none"> • REQUIRED— unless bulk drying 	
			<ul style="list-style-type: none"> • Permanently installed • 10 ports 	<ul style="list-style-type: none"> • REQUIRED— 86 liters/minute or larger displacement 	<ul style="list-style-type: none"> • REQUIRED— unless bulk drying 	
			<ul style="list-style-type: none"> • Permanently installed • 10 ports 	<ul style="list-style-type: none"> • REQUIRED— 86 liters/minute or larger displacement 	<ul style="list-style-type: none"> • REQUIRED— unless bulk drying 	
			<ul style="list-style-type: none"> • REQUIRED— See drying accessories on pages 34-42. 	<ul style="list-style-type: none"> • REQUIRED— 144 liters/minute or larger displacement 	<ul style="list-style-type: none"> • REQUIRED— unless bulk drying 	
<ul style="list-style-type: none"> • Available 	<ul style="list-style-type: none"> • Available 	<ul style="list-style-type: none"> • Available with -50° C models only 	<ul style="list-style-type: none"> • REQUIRED— See drying accessories on pages 34-42. 	<ul style="list-style-type: none"> • REQUIRED— 144 liters/minute or larger displacement 	<ul style="list-style-type: none"> • REQUIRED— unless bulk drying 	
<ul style="list-style-type: none"> • Available 	<ul style="list-style-type: none"> • Available 		<ul style="list-style-type: none"> • REQUIRED— See drying accessories on pages 34-42. 	<ul style="list-style-type: none"> • REQUIRED— 144 liters/minute or larger displacement 	<ul style="list-style-type: none"> • REQUIRED— unless bulk drying 	
<ul style="list-style-type: none"> • Available 	<ul style="list-style-type: none"> • Available 		<ul style="list-style-type: none"> • REQUIRED— See drying accessories on pages 34-42. 	<ul style="list-style-type: none"> • REQUIRED— 144 liters/minute or larger displacement 	<ul style="list-style-type: none"> • REQUIRED— unless bulk drying 	



FreeZone® 1 Liter Benchtop Freeze Dry Systems

FEATURES & BENEFITS

Rear-mounted 3/4" vacuum connection extends vertically, requiring less space.

❖ **Benchtop cabinet** has small footprint. Compact cabinet of durable epoxy-coated steel with brushed stainless steel front panel and four rubber feet fits easily atop a countertop or laboratory cart.

Attachment lid makes connection of accessories easy. Select from accessory drying chambers and manifolds (sold separately).

Upright, stainless steel collector chamber speeds and simplifies defrost. Hot water may be poured into the chamber, or collected ice may be allowed to melt overnight. Models are available with Teflon-coated collector coil and chamber for additional corrosion resistance.

CFC-free refrigeration system ensures rapid, environmentally-safe cooling. The condensing module cools the collector coil to -50° C (-58° F), ideal for freeze drying aqueous samples. The system uses a non-flammable refrigerant that contains no ozone-damaging chlorofluorocarbons (CFCs).

Factory wired. All models include a 3-wire cord with 20 amp NEMA plug.

❖ **LCD** displays system set-up and operating parameters.

Easy-to-follow operating instructions are printed on the right-hand side.

Automatic start-up is quick and easy to use. Turning on the main power switch, located on the right-hand side, initiates the collector cool-down and vacuum pull-down sequence if automatic mode is selected. If manual mode is selected, turning on the main power switch initiates collector cool-down, but the vacuum pump must be turned on by pressing the vacuum switch.

Collector drain hose is accessible from the left-hand side for convenient disposal of defrosted material. It extends about nine inches and retracts within the cabinet when not in use.



ETL listed. Models for operation on 115 volts, 60 Hz or 230 volts, 60 Hz carry the ETL mark signifying they are certified to UL Standard 61010A-1 and CAN/CSA C22.2 No. 1010.1.

Rear-mounted electrical receptacle allows connection of the vacuum pump (pump sold separately).



CE marking. All 220/240 volt, 50 Hz models conform to the CE (European Community) requirements for electrical safety and electromagnetic compatibility.

❖ *Exclusive feature*



FreeZone® 1 Liter Benchtop Freeze Dry Systems

SPECIFICATIONS & ORDERING INFORMATION

All models feature:

- Upright stainless steel collector coil capable of removing 1 liter of water in 24 hours and holding 1 liter of ice before defrosting.
- 1/4 hp CFC-free refrigeration system to cool collector to -50° C (-58° F).
- ❖ Compact benchtop design with a small footprint.
- ❖ Brushed stainless steel and glacier white, epoxy-coated steel exterior with blue accents.
- ❖ LCD for display of set-up and operating parameters. It may be user-configured to select either automatic or manual mode operation and to display vacuum in mBar, Pa or Torr and temperature in ° F or ° C. It also displays total duration of refrigeration system operation and time since the refrigeration system was serviced, and the duration of vacuum pump operation and time since the vacuum pump was serviced (in hours).
- Automatic start-up for collector cool-down and vacuum pull-down when programmed for automatic mode.
- Side-mounted, retractable, 9" collector drain hose.
- Clear acrylic lid, 3/4" thick, with 3" diameter attachment port for connection of drying accessories (sold separately).
- Side-mounted power switch and rear-mounted electrical receptacle (for vacuum pump connection).
- 3/4" OD vacuum connector, three feet of 3/4" ID vacuum hose and two clamps.
- Overall dimensions: 12.6" w x 17.9" d x 16.9" h (32.0 cm x 45.4 cm x 42.9 cm).

Models conform to the following standards:

- UL Standard 61010A-1 (60 Hz models).
- CAN/CSA C22.2 No. 1010.1 (60 Hz models).
- CE Conformity marking (220/240 volts, 50 Hz models).

Options include:

- Teflon-coated collector coil and chamber for processes involving corrosive compounds.
- Domestic or international electrical configuration. Models wired for 115 volts, 60 Hz include a 3-wire cord with 20 amp NEMA 5-20P plug. Models wired for 220/240 volts, 50 Hz or 208/230 volts, 60 Hz include a 3-wire cord with 20 amp NEMA 6-20P plug.

All models require (not included):

- Vacuum pump with a displacement of at least 86 liters per minute, 0.002 mBar ultimate pressure and fitting suitable for 3/4" ID vacuum hose. See pages 44-46.
- Drying accessory. See pages 40-42.
- Freeze dry glassware if not bulk freeze drying. See pages 48-51.



FreeZone 1 Liter Benchtop Freeze Dry System 7740020, 12-Port Drying Chamber 7522800, General Purpose Vacuum Pump 7438700, Portable Table 8025000 and miscellaneous glassware.

Catalog Number	Electrical Requirements (without vacuum pump)	Teflon-Coated Collector Coil & Chamber	Shipping Weight
7740020	115V, 60 Hz, 6.0 A		82 lbs. (37 kg)
7740021	115V, 60 Hz, 6.0 A	•	82 lbs. (37 kg)
7740040	208/230V, 60 Hz, 2.5 A		82 lbs. (37 kg)
7740041	208/230V, 60 Hz, 2.5 A	•	82 lbs. (37 kg)
7740030*	220/240V, 50 Hz, 2.5 A		82 lbs. (37 kg)
7740031*	220/240V, 50 Hz, 2.5 A	•	82 lbs. (37 kg)

❖ Exclusive feature

* International electrical configuration



FreeZone® 2.5 Liter Benchtop Freeze Dry Systems

FEATURES & BENEFITS

CFC-free refrigeration system ensures rapid, environmentally-safe cooling. The condensing module cools the collector coil to -50° C (-58° F), ideal for freeze drying aqueous samples. The system uses a non-flammable refrigerant that contains no ozone-damaging chlorofluorocarbons (CFCs).

Rear-mounted 3/4" vacuum connection extends vertically, requiring less space.

Attachment lid makes connection of accessories easy. Select from accessory drying chambers and manifolds (sold separately).

Upright, stainless steel collector chamber speeds and simplifies defrost. Hot water may be poured into the chamber, or collected ice may be allowed to melt overnight. Models are available with Teflon-coated collector coil and chamber for additional corrosion resistance.

❖ **LCD** displays system set-up and operating parameters and alarm messages.

Easy-to-follow operating instructions are printed on the right-hand side.

Rear-mounted electrical receptacle allows connection of the vacuum pump (pump sold separately).

Automatic start-up is quick and easy to use. Pressing one button initiates the collector cool-down and vacuum pull-down sequence. Or, manually override this feature at any time using the separate switches for manual refrigeration and vacuum.

Collector drain hose is accessible from the left-hand side for convenient defrost. It extends about nine inches and retracts within the cabinet when not in use.

Rear-mounted RS-232 port may be used to transmit data to a user-supplied computer. The time between data transmissions may be set to occur at 10, 30, 60, 300 or 600 second intervals.

Factory wired. All models include a 3-wire cord with 20 amp NEMA plug.

❖ **Vacuum break valve** protects the system from oil backstreaming by bleeding air into the system when power to the freeze dryer or vacuum pump is shut off. If a brief power outage occurs (< approximately 5 minutes), the freeze dryer will restart and the refrigeration and vacuum system will resume operation once power is restored. If the power failure is long (> approximately 5 minutes) and the collector warms above safe limits, the freeze dryer will not automatically restart, which prevents melted sample from being drawn into the collector and liquid from harming the vacuum pump.

Vacuum and temperature graphs display relative system vacuum and collector temperature. Amber LED "waves" illuminate when vacuum and temperature levels are out of range for adding samples. Green LED lights indicate that conditions are right to add samples.

❖ **Red alarm light** flashes and beeper sounds to indicate that an abnormal system event has occurred. Pressing the Menu Switch displays the alarm message on the LCD.

Vacuum control valve maintains setpoint vacuum level to speed the freeze dry process.

❖ **Moisture sensor** protects the vacuum pump by preventing refrigeration or vacuum start-up when moisture is detected in the collector chamber area.

❖ **Benchtop cabinet** has small footprint. Compact cabinet of durable epoxy-coated steel with brushed stainless steel front panel and four rubber feet fits easily atop a countertop or laboratory cart.



ETL listed. Models for operation on 115 volts, 60 Hz or 230 volts, 60 Hz carry the ETL mark signifying they are certified to UL Standard 61010A-1 and CAN/CSA C22.2 No. 1010.1.



CE marking. All 220/240 volt, 50 Hz models conform to the CE (European Community) requirements for electrical safety and electromagnetic compatibility.

❖ *Exclusive feature*



FreeZone® 2.5 Liter Benchtop Freeze Dry Systems

SPECIFICATIONS & ORDERING INFORMATION

All models feature:

- Upright stainless steel collector coil capable of removing 2 liters of water in 24 hours and holding 2.5 liters of ice before defrosting.
- 1/4 hp CFC-free refrigeration system to cool collector to -50° C (-58° F).
- ❖ Compact benchtop design with a small footprint.
- ❖ Brushed stainless steel and glacier white, epoxy-coated steel exterior with blue accents.
- ❖ LCD that displays system operating parameters, set-up parameters and alarm messages. It may be user-configured to display vacuum in mBar, Pa or Torr and temperature in ° F or ° C. It also displays total number of hours of refrigeration system operation and time since the refrigeration system was serviced and the total number of hours of vacuum pump operation and time since the vacuum pump was serviced (in hours).
- ❖ Red alarm light that flashes and beeper that sounds to indicate that an abnormal system event has occurred, including: power failure, improper line voltage supply, collector temperature rise above -40° C, service vacuum pump (after 1000 hours of vacuum use), and moisture in collector. Pressing the Menu Switch displays the alarm message on the LCD.
- LED vacuum and temperature “waves” for at-a-glance display of relative system vacuum and collector temperature.
- ❖ Moisture sensor that prevents refrigeration or vacuum start-up when moisture is detected in the collector chamber area.
- Vacuum control valve that maintains setpoint vacuum level.
- ❖ Vacuum break valve that bleeds air into the system when power to the freeze dryer or vacuum pump is shut off. If a power outage less than approximately 5 minutes occurs, the freeze dryer will restart and the refrigeration and vacuum system will resume operation once power is restored. If the power failure is more than approximately 5 minutes and the collector warms above safe limits, the freeze dryer will not automatically restart.
- Rear-mounted RS-232 port to transmit data to a user-supplied computer. Transmission intervals may be user-configured for 10, 30, 60, 300 or 600 seconds.
- Automatic start-up switch for collector cool-down and vacuum pull-down with manual override switches.
- Side-mounted, retractable, 9" collector drain hose.
- Clear acrylic lid, 3/4" thick, with 3" diameter port for connection of drying accessories (sold separately).
- Side-mounted power switch and rear-mounted electrical receptacle (for vacuum pump connection).
- 3/4" OD vacuum connection, three feet of 3/4" ID vacuum hose and two clamps.
- Overall dimensions: 12.6" w x 17.9" d x 16.9" h (32.0 cm x 45.4 cm x 42.9 cm).

Models conform to the following standards:

- UL Standard 61010A-1 (60 Hz models).
- CAN/CSA C22.2 No. 1010.1 (60 Hz models).
- CE Conformity marking (220/240 volts, 50 Hz models).

Options include:

- Teflon-coated collector coil and chamber for processes involving corrosive compounds.
- Domestic or international electrical configuration. Models wired for 115 volts, 60 Hz include a 3-wire cord with 20 amp NEMA 5-20P plug. Models wired for 220/240 volts, 50 Hz or 208/230 volts, 60 Hz include a 3-wire cord with 20 amp NEMA 6-20P plug.



FreeZone 2.5 Liter Benchtop Freeze Dry System 7670520, Clear Chamber with Valves 7443500, General Purpose Vacuum Pump 7438700, Portable Table 8025000 and miscellaneous glassware.

All models require (not included):

- Vacuum pump with a displacement of at least 86 liters per minute, 0.002 mBar ultimate pressure and fitting suitable for 3/4" ID vacuum hose. See pages 44-46.
- Drying accessory. See pages 40-42.
- Freeze dry glassware if not bulk freeze drying. See pages 48-51.

Catalog Number	Electrical Requirements (without vacuum pump)	Teflon-Coated Collector Coil & Chamber	Shipping Weight
7670520	115V, 60 Hz, 6.0 A		82 lbs. (37 kg)
7670521	115V, 60 Hz, 6.0 A	•	82 lbs. (37 kg)
7670540	208/230V, 60 Hz, 2.5 A		82 lbs. (37 kg)
7670541	208/230V, 60 Hz, 2.5 A	•	82 lbs. (37 kg)
7670530*	220/240V, 50 Hz, 2.5 A		82 lbs. (37 kg)
7670531*	220/240V, 50 Hz, 2.5 A	•	82 lbs. (37 kg)

❖ Exclusive feature

* International electrical configuration



FreeZone® Plus 2.5 Liter Cascade Benchtop Freeze Dry Systems

FEATURES & BENEFITS

CFC/HCFC-free refrigeration system ensures rapid, environmentally-safe cooling. Two condensing modules, used in series, cool the collector coil to **-84° C (-119° F)**, ideal for freeze drying samples with low eutectic points. The systems use a non-flammable refrigerant that contains no ozone-damaging chlorofluorocarbons (CFCs) or hydrochlorofluorocarbons (HCFCs).

Rear-mounted 3/4" vacuum connection extends vertically, requiring less space.

Attachment lid makes connection of accessories easy. Select from accessory drying chambers and manifolds (sold separately).

Upright, stainless steel collector chamber speeds and simplifies defrost. A baffle maximizes ice loading capabilities by evenly distributing collected ice over the entire collector coil. Hot water may be poured into the chamber, or collected ice may be allowed to melt overnight. Models are available with Teflon-coated collector coil and chamber for additional corrosion resistance.

❖ **LCD** displays system set-up and operating parameters and alarm messages.

Easy-to-follow operating instructions are printed on the right-hand side.

Rear-mounted electrical receptacle allows connection of the vacuum pump (pump sold separately).

Automatic start-up is quick and easy to use. Pressing one button initiates the collector cool-down and vacuum pull-down sequence. Or, manually override this feature at any time using the separate switches for manual refrigeration and vacuum.

Collector drain hose is accessible from the left-hand side for convenient disposal of defrosted material. It extends about nine inches and retracts within the cabinet when not in use.

Rear-mounted RS-232 port may be used to transmit data to a user-supplied computer. The time between data transmissions may be set to occur at 10, 30, 60, 300 or 600 second intervals.

❖ **Vacuum break valve** protects the system from oil backstreaming by bleeding air into the system when power to the freeze dryer or vacuum pump is shut off. If a brief power outage occurs (< approximately 5 minutes), the freeze dryer will restart and the refrigeration and vacuum system will resume operation once power is restored. If the power failure is long (> approximately 5 minutes) and the collector warms above safe limits, the freeze dryer will not automatically restart, which prevents melted sample from being drawn into the collector and liquid from harming the vacuum pump.

Vacuum and temperature graphs display relative system vacuum and collector temperature. Amber LED "waves" illuminate when vacuum and temperature levels are out of range for adding samples. Green LED lights indicate that conditions are right to add samples.

❖ **Red alarm light** flashes and beeper sounds to indicate that an abnormal system event has occurred. Pressing the Menu Switch displays the alarm message on the LCD.

Vacuum control valve maintains setpoint vacuum level to speed the freeze dry process.

❖ **Moisture sensor** protects the vacuum pump by preventing refrigeration or vacuum start-up when moisture is detected in the collector chamber area.

❖ **Benchtop cabinet** has small footprint. Compact cabinet of durable epoxy-coated steel with brushed stainless steel front panel and four rubber feet fits easily atop a countertop or laboratory cart.

Factory wired. All models include a 3-wire cord with 20 amp NEMA plug.

❖ *Exclusive feature*



ETL listed. Models for operation on 115 volts, 60 Hz or 230 volts, 60 Hz carry the ETL mark signifying they are certified to UL Standard 61010A-1 and CAN/CSA C22.2 No. 1010.1.



CE marking. All 220/240 volt, 50 Hz models conform to the CE (European Community) requirements for electrical safety and electromagnetic compatibility.



FreeZone® Plus 2.5 Liter Cascade Benchtop Freeze Dry Systems

SPECIFICATIONS & ORDERING INFORMATION

All models feature:

- Upright stainless steel collector coil with molded plastic baffle capable of removing 1.8 liters of water in 24 hours and holding 2.5 liters of ice before defrosting.
- Dual CFC- and HCFC-free refrigeration systems, one 1/4 hp and one 1/3 hp, to cool collector to **-84° C (-119° F)**.
- ❖ Compact benchtop cabinet with small footprint.
- ❖ Brushed stainless steel and glacier white, epoxy-coated steel exterior with blue accents.
- ❖ LCD that displays system operating parameters, set-up parameters and alarm messages. It may be user-configured to display vacuum in mBar, Pa or Torr and temperature in ° F or ° C. It also displays total number of hours of refrigeration system operation and time since the refrigeration system was serviced, and the total number of hours of vacuum pump operation and time since the vacuum pump was serviced (in hours).
- ❖ Red alarm light that flashes and beeper that sounds to indicate that an abnormal system event has occurred, including: power failure, improper line voltage supply, collector temperature rise above -40° C, service vacuum pump (after 1000 hours of vacuum use), and moisture in collector. Pressing the Menu Switch displays the alarm message on the LCD.
- LED vacuum and temperature “waves” for at-a-glance display of relative system vacuum and collector temperature.
- ❖ Moisture sensor that prevents refrigeration or vacuum start-up when moisture is detected in the collector chamber area.
- Vacuum control valve that maintains setpoint vacuum level.
- ❖ Vacuum break valve that bleeds air into the system when power to the freeze dryer or vacuum pump is shut off. If a power outage less than approximately 5 minutes occurs, the freeze dryer will restart and the refrigeration and vacuum system will resume operation once power is restored. If the power failure is more than approximately 5 minutes and the collector warms above safe limits, the freeze dryer will not automatically restart.
- Rear-mounted RS-232 port to transmit data to a user-supplied computer. Transmission intervals may be user-configured for 10, 30, 60, 300 or 600 seconds.
- Automatic start-up switch for collector cool-down and vacuum pull-down with manual override switches.
- Side-mounted, retractable, 9" collector drain hose.
- Clear acrylic lid, 3/4" thick, with 3" diameter port for connection of drying accessories (sold separately).
- Side-mounted power switch and rear-mounted electrical receptacle (for vacuum pump connection).
- 3/4" OD vacuum connector, three feet of 3/4" ID vacuum hose and two clamps.
- Overall dimensions: 15.1" w x 23.2" d x 16.9" h (38.3 cm x 59.0 cm x 42.9 cm).

Models conform to the following standards:

- UL Standard 61010A-1 (60 Hz models).
- CAN/CSA C22.2 No. 1010.1 (60 Hz models).
- CE Conformity marking (220/240 volts, 50 Hz models).

Options include:

- Teflon-coated collector coil and chamber for processes involving corrosive compounds.
- Domestic or international electrical configuration. Models wired for 115 volts, 60 Hz include a 3-wire cord with 20 amp NEMA 5-20P plug. Models wired for 220/240 volts, 50 Hz or 208/230 volts, 60 Hz include a 3-wire cord with 20 amp NEMA 6-20P plug.



FreeZone Plus 2.5 Liter Cascade Benchtop Freeze Dry System 7670020, 20-Port Manifold 7522300, General Purpose Vacuum Pump 7438700, Variable Height Bench 8075000 and miscellaneous glassware.

All models require (not included):

- Vacuum pump with a displacement of at least 86 liters per minute, 0.002 mBar ultimate pressure and fitting suitable for 3/4" ID vacuum hose. See pages 44-46.
- Drying accessory. See pages 40-42.
- Freeze dry glassware if not bulk freeze drying. See pages 48-51.

Catalog Number	Electrical Requirements (without vacuum pump)	Teflon-Coated Collector Coil & Chamber	Shipping Weight
7670020	115V, 60 Hz, 10.0 A		121 lbs. (55 kg)
7670021	115V, 60 Hz, 10.0 A	•	121 lbs. (55 kg)
7670040	208/230V, 60 Hz, 5.1 A		121 lbs. (55 kg)
7670041	208/230V, 60 Hz, 5.1 A	•	121 lbs. (55 kg)
7670030*	220/240V, 50 Hz, 5.1 A		121 lbs. (55 kg)
7670031*	220/240V, 50 Hz, 5.1 A	•	121 lbs. (55 kg)

❖ Exclusive feature

* International electrical configuration



FreeZone® Plus 2.5 Liter Cascade Freeze Dry Systems

FEATURES & BENEFITS

❖ **Moisture sensor** protects the vacuum pump by preventing refrigeration or vacuum start-up when moisture is detected in the collector chamber area.

Rear-mounted 3/4" vacuum connection extends vertically, requiring less space.

❖ **LCD** displays system set-up and operating parameters and alarm messages.

Collector drain hose is accessible from the left-hand side for convenient disposal of defrosted material. It extends about nine inches and retracts within the cabinet when not in use.

Rear-mounted electrical receptacle allows connection of the vacuum pump (pump sold separately).

❖ **Compact console cabinet.** Cabinet, mounted on 3" diameter casters, is epoxy-coated steel with removable brushed stainless steel front panel. The interior accommodates a vacuum pump (pump sold separately.)

Easy-to-follow operating instructions are printed on the right hand side.

❖ **Vacuum break valve** protects the system from oil back-streaming by bleeding air into the system when power to the freeze dryer or vacuum pump is shut off. If a brief power outage occurs (< approximately 5 minutes), the freeze dryer will restart and the refrigeration and vacuum system will resume operation once power is restored. If the power failure is long (> approximately 5 minutes) and the collector warms above safe limits, the freeze dryer will not automatically restart, which prevents melted sample from being drawn into the collector and liquid from harming the vacuum pump.

Automatic start-up is quick and easy to use. Pressing one button initiates the collector cool-down and vacuum pull-down sequence. Or, manually override this feature at any time using the separate switches for manual refrigeration and vacuum.

Attachment lid makes connection of accessories easy. Select from accessory drying chambers and manifolds (sold separately).

Upright, stainless steel collector chamber speeds and simplifies defrost. A baffle maximizes ice loading capabilities by evenly distributing collected ice over the entire collector coil. Hot water may be poured into the chamber, or collected ice may be allowed to melt overnight. Models are available with Teflon-coated collector chamber and coils for additional corrosion resistance.

Vacuum and temperature graphs display relative system vacuum and collector temperature. Amber LED "waves" illuminate when vacuum and temperature levels are out of range for adding samples. Green LED lights indicate that conditions are right to add samples.

❖ **Red alarm light** flashes and beeper sounds to indicate that an abnormal system event has occurred. Pressing the Menu Switch displays the alarm message on the LCD.

CFC/HCFC-free refrigeration system ensures rapid, environmentally-safe cooling. Two condensing modules, used in series, cool the collector coil to **-84° C (-119° F)**, ideal for freeze drying samples with low eutectic points. The systems use a non-flammable refrigerant that contains no ozone-damaging chlorofluorocarbons (CFCs) or hydrochlorofluorocarbons (HCFCs).

Factory wired. All models include a 3-wire cord with 20 amp NEMA plug.

Rear-mounted RS-232 port may be used to transmit data to a user-supplied computer. The time between data transmissions may be set to occur at 10, 30, 60, 300 or 600 second intervals.



ETL listed. Models for operation on 115 volts, 60 Hz or 230 volts, 60 Hz carry the ETL mark signifying they are certified to UL Standard 61010A-1 and CAN/CSA C22.2 No. 1010.1.



CE marking. All 220/240 volt, 50 Hz models conform to the CE (European Community) requirements for electrical safety and electromagnetic compatibility.

Vacuum control valve maintains setpoint vacuum level to speed the freeze dry process.

❖ *Exclusive feature*



FreeZone® Plus 2.5 Liter Cascade Freeze Dry Systems

SPECIFICATIONS & ORDERING INFORMATION

All models feature:

- Upright stainless steel collector coil with molded plastic baffle capable of removing 1.8 liters of water in 24 hours and holding 2.5 liters of ice before defrosting.
- Dual CFC- and HCFC-free refrigeration systems, one 1/4 hp and one 1/3 hp, to cool collector to **-84° C (-119° F)**.
- ❖ Compact console cabinet with 3" diameter casters.
- ❖ Brushed stainless steel and glacier white, epoxy-coated steel exterior with blue accents.
- ❖ LCD that displays system operating parameters, set-up parameters and alarm messages. It may be user-configured to display vacuum in mBar, Pa or Torr and temperature in ° F or ° C. It also displays total number of hours of refrigeration system operation and time since the refrigeration system was serviced, and the total number of hours of vacuum pump operation and time since the vacuum pump was serviced (in hours).
- ❖ Red alarm light that flashes and beeper that sounds to indicate that an abnormal system event has occurred, including: power failure, improper line voltage supply, collector temperature rise above -40° C, service vacuum pump (after 1000 hours of vacuum use), and moisture in collector. Pressing the Menu Switch displays the alarm message on the LCD.
- LED vacuum and temperature "waves" for at-a-glance display of relative system vacuum and collector temperature.
- ❖ Moisture sensor that prevents refrigeration or vacuum start-up when moisture is detected in the collector chamber area.
- Vacuum control valve that maintains setpoint vacuum level.
- ❖ Vacuum break valve that bleeds air into the system when power to the freeze dryer or vacuum pump is shut off. If a power outage less than approximately 5 minutes occurs, the freeze dryer will restart and the refrigeration and vacuum system will resume operation once power is restored. If the power failure is more than approximately 5 minutes and the collector warms above safe limits, the freeze dryer will not automatically restart.
- Rear-mounted RS-232 port to transmit data to a user-supplied computer. Transmission intervals may be user-configured for 10, 30, 60, 300 or 600 seconds.
- Automatic start-up switch for collector cool-down and vacuum pull-down with manual override switches.
- Side-mounted, retractable, 9" collector drain hose.
- Clear acrylic lid, 3/4" thick, with 3" diameter port for connection of drying accessories (sold separately).
- Side-mounted power switch and rear-mounted electrical receptacle (for vacuum pump connection).
- 3/4" OD vacuum connector, three feet of 3/4" ID vacuum hose and two clamps.
- Overall dimensions: 18.6" w x 23.2" d x 37.4" h (47.2 cm x 59.0 cm x 95.0 cm).
- Usable interior space: 14.0" w x 18.5" d x 16.0" h (35.6 cm x 47.0 cm x 40.6 cm).

Models conform to the following standards:

- UL Standard 61010A-1 (60 Hz models).
- CAN/CSA C22.2 No. 1010.1 (60 Hz models).
- CE Conformity marking (220/240 volts, 50 Hz models).

Options include:

- Teflon-coated collector coil and chamber for processes involving corrosive compounds.
- Domestic or international electrical configuration. Models wired for 115 volts, 60 Hz include a 3-wire cord with 20 amp NEMA 5-20P plug. Models wired for 220/240 volts, 50 Hz or 208/230 volts, 60 Hz include a 3-wire cord with 20 amp NEMA 6-20P plug.



FreeZone Plus 2.5 Liter Cascade Freeze Dry System 7420020, Clear Chamber with Valves 7443500, Product Shelves 7442100 and miscellaneous glassware.

All models require (not included):

- Vacuum pump with a displacement of at least 86 liters per minute, 0.002 mBar ultimate pressure and fitting suitable for 3/4" ID vacuum hose. See pages 44-46.
- Drying accessory. See pages 38-40.
- Freeze dry glassware if not bulk freeze drying. See pages 48-51.

Catalog Number	Electrical Requirements (without vacuum pump)	Teflon-Coated Collector Coil & Chamber	Shipping Weight
7420020	115V, 60 Hz, 10.0 A		171 lbs. (78 kg)
7420021	115V, 60 Hz, 10.0 A	•	171 lbs. (78 kg)
7420040	208/230V, 60 Hz, 5.1 A		171 lbs. (78 kg)
7420041	208/230V, 60 Hz, 5.1 A	•	171 lbs. (78 kg)
7420030*	220/240V, 50 Hz, 5.1 A		171 lbs. (78 kg)
7420031*	220/240V, 50 Hz, 5.1 A	•	171 lbs. (78 kg)

❖ Exclusive feature

* International electrical configuration



FreeZone® 4.5 Liter Benchtop Freeze Dry Systems

FEATURES & BENEFITS

Permanently-installed drying chamber facilitates sample connection. The stainless steel chamber includes ten valves to allow connection of serum bottles, ampules or freeze dry flasks with 1/2" or 3/4" adapters. Each valve has a beveled edge to provide at-a-glance indication of whether the valve is open or closed. The clear acrylic lid permits easy monitoring of ice build-up on the collector.

Rear-mounted 3/4" vacuum connection extends vertically, requiring less space.

Upright, stainless steel collector chamber speeds and simplifies defrost. Hot water may be poured into the chamber, or collected ice may be allowed to melt overnight. Models are available with Teflon-coated collector coil and chamber for additional corrosion resistance.

CFC-free refrigeration system ensures rapid, environmentally-safe cooling. The condensing module cools the collector coil to -50° C (-58° F), ideal for freeze drying aqueous samples. The system uses a non-flammable refrigerant that contains no ozone-damaging chlorofluorocarbons (CFCs).

Easy-to-follow operating instructions are printed on the right-hand side.

Vacuum control valve maintains setpoint vacuum level to speed the freeze dry process.

✱ **LCD** displays system set-up and operating parameters and alarm messages.

Rear-mounted electrical receptacle allows connection of the vacuum pump (pump sold separately).

Automatic start-up is quick and easy to use. Pressing one button initiates the collector cool-down and vacuum pull-down sequence. Or, manually override this feature at any time using the separate switches for manual refrigeration and vacuum.

Collector drain hose is accessible from the left-hand side for convenient defrost. It extends about nine inches and retracts within the cabinet when not in use.

Rear-mounted RS-232 port may be used to transmit data to a user-supplied computer. The time between data transmissions may be set to occur at 10, 30, 60, 300 or 600 second intervals.

Factory wired. All models include a 3-wire cord with 20 amp NEMA plug.

✱ *Exclusive feature*

✱ **Vacuum break valve** protects the system from oil back-streaming by bleeding air into the system when power to the freeze dryer or vacuum pump is shut off. If a brief power outage occurs (< approximately 5 minutes), the freeze dryer will restart and the refrigeration and vacuum system will resume operation once power is restored. If the power failure is long (> approximately 5 minutes) and the collector warms above safe limits, the freeze dryer will not automatically restart, which prevents melted sample from being drawn into the collector and liquid from harming the vacuum pump.

Vacuum and temperature graphs display relative system vacuum and collector temperature. Amber LED "waves" illuminate when vacuum and temperature levels are out of range for adding samples. Green LED lights indicate that conditions are right to add samples.

Red alarm light flashes and beeper sounds to indicate that an abnormal system event has occurred. Pressing the Menu Switch displays the alarm message on the LCD.

✱ **Moisture sensor** protects the vacuum pump by preventing refrigeration or vacuum start-up when moisture is detected in the collector chamber area.

✱ **Benchtop cabinet has small footprint.** Compact cabinet of durable epoxy-coated steel with brushed stainless steel front panel and four rubber feet fits easily atop a countertop or laboratory cart.



ETL listed. Models for operation on 115 volts, 60 Hz or 230 volts, 60 Hz carry the ETL mark signifying they are certified to UL Standard 61010A-1 and CAN/CSA C22.2 No. 1010.1.



CE marking. All 220/240 volt, 50 Hz models conform to the CE (European Community) requirements for electrical safety and electromagnetic compatibility.



FreeZone® 4.5 Liter Benchtop Freeze Dry Systems

SPECIFICATIONS & ORDERING INFORMATION

All models feature:

- Upright stainless steel collector coil capable of removing 2 liters of water in 24 hours and holding 4.5 liters of ice before defrosting.
- 1/3 hp CFC-free refrigeration system to cool collector to -50° C (-58° F).
- Permanently-installed 10-port stainless steel drying chamber with 1/2" thick, clear acrylic lid with neoprene gasket.
- Compact benchtop design with a small footprint.
- ❖ Brushed stainless steel and glacier white, epoxy-coated steel exterior with blue accents.
- ❖ LCD that displays system operating parameters, set-up parameters and alarm messages. It may be user-configured to display vacuum in mBar, Pa or Torr and temperature in ° F or ° C. It also displays total number of hours of refrigeration system operation and time since the refrigeration system was serviced and the total number of hours of vacuum pump operation and time since the vacuum pump was serviced (in hours).
- ❖ Red alarm light that flashes and beeper that sounds to indicate that an abnormal system event has occurred, including: power failure, improper line voltage supply, collector temperature rise above -40° C, service vacuum pump (after 1000 hours of vacuum use), and moisture in collector. Pressing the Menu Switch displays the alarm message on the LCD.
- LED vacuum and temperature “waves” for at-a-glance display of relative system vacuum and collector temperature.
- ❖ Moisture sensor that prevents refrigeration or vacuum start-up when moisture is detected in the collector chamber area.
- Vacuum control valve that maintains setpoint vacuum level.
- ❖ Vacuum break valve that bleeds air into the system when power to the freeze dryer or vacuum pump is shut off. If a power outage less than approximately 5 minutes occurs, the freeze dryer will restart and the refrigeration and vacuum system will resume operation once power is restored. If the power failure is more than approximately 5 minutes and the collector warms above safe limits, the freeze dryer will not automatically restart.
- Rear-mounted RS-232 port to transmit data to a user-supplied computer. Transmission intervals may be user-configured for 10, 30, 60, 300 or 600 seconds.
- Automatic start-up switch for collector cool-down and vacuum pull-down with manual override switches.
- Side-mounted, retractable, 9" collector drain hose.
- Side-mounted power switch and rear-mounted electrical receptacle (for vacuum pump connection).
- 3/4" OD vacuum connection, three feet of 3/4" ID vacuum hose and two clamps.
- Overall dimensions: 18.6" w x 18.5" d x 22.5" h (47.2 cm x 47 cm x 57.2 cm).

Models conform to the following standards:

- UL Standard 61010A-1 (60 Hz models).
- CAN/CSA C22.2 No. 1010.1 (60 Hz models).
- CE Conformity marking (220/240 volts, 50 Hz models).

Options include:

- Teflon-coated collector coil and chamber for processes involving corrosive compounds.
- Domestic or international electrical configuration. Models wired for 115 volts, 60 Hz include a 3-wire cord with 20 amp NEMA 5-20P plug. Models wired for 220/240 volts, 50 Hz or 208/230 volts, 60 Hz include a 3-wire cord with 20 amp NEMA 6-20P plug.



FreeZone 4.5 Liter Benchtop Freeze Dry System 7750020, Utility Cart 8007000 and Chemical-Resistant Rotary Vane Vacuum Pump 7769600.

All models require (not included):

- Vacuum pump with a displacement of at least 86 liters per minute, 0.002 mBar ultimate pressure, 15 amp NEMA 5-15P plug (115 volt models) or reverse IEC plug (220/240 or 208/230 volt models), and fitting suitable for 3/4" ID vacuum hose. See pages 44-46.
- Freeze dry glassware if not bulk freeze drying. See pages 48-51.

Catalog Number	Electrical Requirements (without vacuum pump)	Teflon-Coated Collector Coil & Chamber	Shipping Weight
7750020	115V, 60 Hz, 6.0 A		102 lbs. (46 kg)
7750021	115V, 60 Hz, 6.0 A	•	102 lbs. (46 kg)
7750040	208/230V, 60 Hz, 2.5 A		102 lbs. (46 kg)
7750041	208/230V, 60 Hz, 2.5 A	•	102 lbs. (46 kg)
7750030*	220/240V, 50 Hz, 2.5 A		102 lbs. (46 kg)
7750031*	220/240V, 50 Hz, 2.5 A	•	102 lbs. (46 kg)

❖ Exclusive feature * International electrical configuration



FreeZone® 4.5 Liter Freeze Dry Systems

FEATURES & BENEFITS

Automatic start-up is quick and easy to use. Pressing one button initiates the collector cool-down and vacuum pull-down sequence. Or, manually override this feature at any time using the separate switches for manual refrigeration and vacuum.

Upright, stainless steel collector chamber speeds and simplifies defrost. Hot water may be poured into the chamber, or collected ice may be allowed to melt overnight. Models are available with Teflon-coated collector chamber and coils for additional corrosion resistance.

CFC-free refrigeration system ensures rapid, environmentally-safe cooling. The condensing module cools the collector coil to -50° C (-58° F), ideal for freeze drying aqueous samples. The system uses a non-flammable refrigerant that contains no ozone-damaging chlorofluorocarbons (CFCs).

Permanently-installed drying chamber facilitates sample connection. The stainless steel chamber includes ten valves to allow connection of serum bottles, ampules or freeze dry flasks with 1/2" or 3/4" adapters. Each valve has a beveled edge to provide at-a-glance indication of whether the valve is open or closed. The clear acrylic lid permits easy monitoring of ice build-up on the collector.

❖ **Moisture sensor** protects the vacuum pump by preventing refrigeration or vacuum start-up when moisture is detected in the collector chamber area.

Rear-mounted 3/4" vacuum connection extends vertically, requiring less space.

❖ **LCD** displays system set-up and operating parameters and alarm messages.

Collector drain hose is accessible from the left-hand side for convenient defrost. It extends about nine inches and retracts within the cabinet when not in use.

Rear-mounted electrical receptacle allows connection of the vacuum pump (pump sold separately).

❖ **Compact console cabinet.** Cabinet, mounted on 3" diameter casters, is epoxy-coated steel with a removable brushed stainless steel front panel. The interior accommodates a vacuum pump (sold separately).

Easy-to-follow operating instructions are printed on the right-hand side.

Factory wired. All models include a 3-wire cord with 20 amp NEMA plug.

Vacuum and temperature graphs display relative system vacuum and collector temperature. Amber LED "waves" illuminate when vacuum and temperature levels are out of range for adding samples. Green LED lights indicate that conditions are right to add samples.

❖ **Red alarm light** flashes and beeper sounds to indicate that an abnormal system event has occurred. Pressing the Menu Switch displays the alarm message on the LCD.

Vacuum control valve maintains setpoint vacuum level to speed the freeze dry process.

Rear-mounted RS-232 port may be used to transmit data to a user-supplied computer. The time between data transmissions may be set to occur at 10, 30, 60, 300 or 600 second intervals.

❖ **Vacuum break valve** protects the system from oil back-streaming by bleeding air into the system when power to the freeze dryer or vacuum pump is shut off. If a brief power outage occurs (< approximately 5 minutes), the freeze dryer will restart and the refrigeration and vacuum system will resume operation once power is restored. If the power failure is long (> approximately 5 minutes) and the collector warms above safe limits, the freeze dryer will not automatically restart, which prevents melted sample from being drawn into the collector and liquid from harming the vacuum pump.



ETL listed. Models for operation on 115 volts, 60 Hz or 230 volts, 60 Hz carry the ETL mark signifying they are certified to UL Standard 61010A-1 and CAN/CSA C22.2 No. 1010.1.



CE marking. All 220/240 volt, 50 Hz models conform to the CE (European Community) requirements for electrical safety and electromagnetic compatibility.

❖ *Exclusive feature*



FreeZone® 4.5 Liter Freeze Dry Systems

SPECIFICATIONS & ORDERING INFORMATION

All models feature:

- Upright stainless steel collector coil capable of removing 2 liters of water in 24 hours and holding 4.5 liters of ice before defrosting.
- 1/3 hp CFC-free refrigeration system to cool collector to -50° C (-58° F).
- Permanently-installed 10-port stainless steel drying chamber with 1/2" thick, clear acrylic lid with neoprene gasket.
- ❖ Brushed stainless steel and glacier white, epoxy-coated steel exterior with blue accents.
- ❖ LCD that displays system operating parameters, set-up parameters and alarm messages. It may be user-configured to display vacuum in mBar, Pa or Torr and temperature in ° F or ° C. It also displays total number of hours of refrigeration system operation and time since the refrigeration system was serviced and the total number of hours of vacuum pump operation and time since the vacuum pump was serviced (in hours).
- ❖ Red alarm light that flashes and beeper that sounds to indicate that an abnormal system event has occurred, including: power failure, improper line voltage supply, collector temperature rise above -40° C, service vacuum pump (after 1000 hours of vacuum use), and moisture in collector. Pressing the Menu Switch displays the alarm message on the LCD.
- LED vacuum and temperature "waves" for at-a-glance display of relative system vacuum and collector temperature.
- ❖ Moisture sensor that prevents refrigeration or vacuum start-up when moisture is detected in the collector chamber area.
- Vacuum control valve that maintains setpoint vacuum level.
- ❖ Vacuum break valve that bleeds air into the system when power to the freeze dryer or vacuum pump is shut off. If a power outage less than approximately 5 minutes occurs, the freeze dryer will restart and the refrigeration and vacuum system will resume operation once power is restored. If the power failure is more than approximately 5 minutes and the collector warms above safe limits, the freeze dryer will not automatically restart.
- Rear-mounted RS-232 port to transmit data to a user-supplied computer. Transmission intervals may be user-configured for 10, 30, 60, 300 or 600 seconds.
- Automatic start-up switch for collector cool-down and vacuum pull-down with manual override switches.
- Side-mounted, retractable, 9" collector drain hose.
- Side-mounted power switch and rear-mounted electrical receptacle (for vacuum pump connection).
- 3" diameter casters.
- 3/4" OD vacuum connection, three feet of 3/4" ID vacuum hose and two clamps.
- Overall dimensions: 18.6" w x 24.0" d x 48.1" h (47.2 cm x 61.0 cm x 122.2 cm).
- Usable interior space: 14.0" w x 18.5" d x 21.0" h (35.6 cm x 47.0 cm x 53.3 cm).

Models conform to the following standards:

- UL Standard 61010A-1 (60 Hz models).
- CAN/CSA C22.2 No. 1010.1 (60 Hz models).
- CE Conformity marking (220/240 volts, 50 Hz models).

Options include:

- Teflon-coated collector coil and chamber for processes involving corrosive compounds.
- Domestic or international electrical configuration. Models wired for 115 volts, 60 Hz include a 3-wire cord with 20 amp NEMA 5-20P plug. Models wired for 220/240 volts, 50 Hz or 208/230 volts, 60 Hz include a 3-wire cord with 20 amp NEMA 6-20P plug.



FreeZone 4.5 Liter Freeze Dry System 7751020.

All models require (not included):

- Vacuum pump with a displacement of at least 86 liters per minute, 0.002 mBar ultimate pressure, 15 amp NEMA 5-15P plug (115 volt models) or reverse IEC plug (220/240 or 208/230 volt models), and fitting suitable for 3/4" ID vacuum hose. See pages 44-48.
- Freeze dry glassware if not bulk freeze drying. See pages 48-51.

Catalog Number	Electrical Requirements (without vacuum pump)	Teflon-Coated Collector Coil & Chamber	Shipping Weight
7751020	115V, 60 Hz, 6.0 A		162 lbs. (73 kg)
7751021	115V, 60 Hz, 6.0 A	•	162 lbs. (73 kg)
7751040	208/230V, 60 Hz, 2.5 A		162 lbs. (73 kg)
7751041	208/230V, 60 Hz, 2.5 A	•	162 lbs. (73 kg)
7751030*	220/240V, 50 Hz, 2.5 A		162 lbs. (73 kg)
7751031*	220/240V, 50 Hz, 2.5 A	•	162 lbs. (73 kg)

❖ Exclusive feature

* International electrical configuration



FreeZone® 6 Liter Benchtop Freeze Dry Systems

FEATURES & BENEFITS

❖ **Durable benchtop cabinet.**

Cabinet is epoxy-coated steel with a brushed stainless steel front panel and four rubber feet and fits easily atop a countertop or laboratory cart.

Automatic start-up is quick and easy to use. Pressing one button initiates the collector cool-down and vacuum pull-down sequence. Or, manually override this feature at any time using the separate switches for manual refrigeration and vacuum.

Rear-mounted 3/4" vacuum connection extends parallel to the back requiring less space.

Attachment port makes connection of accessories easy. Select from accessory drying chambers and manifolds (sold separately).

Upright, stainless steel collector chamber speeds and simplifies defrost. Hot water may be poured into the chamber, or collected ice may be allowed to melt overnight. Models are available with Teflon-coated collector coil and chamber for additional corrosion resistance.

CFC-free refrigeration system ensures rapid, environmentally-safe cooling. The condensing module cools the collector coil to -50° C (-58° F), ideal for freeze drying aqueous samples. The system uses a non-flammable refrigerant that contains no ozone-damaging chlorofluorocarbons (CFCs).

Easy-to-follow operating instructions are printed on the right-hand side.

❖ **Moisture sensor** protects the vacuum pump by preventing refrigeration or vacuum start-up when moisture is detected in the collector chamber area.

❖ **Vacuum and temperature graphs** display relative system vacuum and collector temperature. Amber LED "waves" illuminate when vacuum and temperature levels are out of range for adding samples. Green LED lights indicate that conditions are right to add samples.

❖ **Red alarm light** flashes and beeper sounds to indicate that an abnormal system event has occurred. Pressing the Menu Switch displays the alarm message on the LCD.

❖ **Factory wired.** All models include a 3-wire cord with 20 amp NEMA plug.

❖ **Rear-mounted electrical receptacle** allows connection of the vacuum pump (pump sold separately).

Collector drain hose is accessible from the right-hand side for convenient defrost. It extends about nine inches and retracts within the cabinet when not in use.

Vacuum control valve maintains setpoint vacuum level to speed the freeze drying process.

❖ **LCD** displays system set-up and operating parameters and alarm messages.

Rear-mounted RS-232 port may be used to transmit data to a user-supplied computer. The time between data transmissions may be set to occur at 10, 30, 60 300 or 600 second intervals.

❖ **Vacuum break valve** protects the system from oil back-streaming by bleeding air into the system when power to the freeze dryer or vacuum pump is shut off. If a brief power outage occurs (< approximately 5 minutes), the freeze dryer will restart and the refrigeration and vacuum system will resume operation once power is restored. If the power failure is long (> approximately 5 minutes) and the collector warms above safe limits, the freeze dryer will not automatically restart, which prevents melted sample from being drawn into the collector and liquid from harming the vacuum pump.



ETL listed. Models for operation on 115 volts, 60 Hz or 208/230 volts, 60 Hz carry the ETL mark signifying they are certified to UL Standard 61010A-1 and CAN/CSA C22.2 No. 1010.1.



CE marking. All 220/240 volt, 50 Hz models conform to the CE (European Community) requirements for electrical safety and electromagnetic compatibility.

❖ *Exclusive feature*



FreeZone® 6 Liter Benchtop Freeze Dry Systems

SPECIFICATIONS & ORDERING INFORMATION

All models feature:

- Upright stainless steel collector coil capable of removing 4 liters of water in 24 hours and holding 6 liters of ice before defrosting.
- 3/4 hp CFC-free refrigeration system to cool collector to -50° C (-58° F).
- ❖ Brushed stainless steel and glacier white, epoxy-coated steel exterior with blue accents.
- ❖ LCD that displays system operating parameters, set-up parameters and alarm messages. It may be user-configured to display vacuum in mBar, Pa or Torr and temperature in ° F or ° C. It also displays total number of hours of refrigeration system operation and time since the refrigeration system was serviced and the total number of hours of vacuum pump operation and time since the vacuum pump was serviced (in hours).
- Red alarm light that flashes and beeper that sounds to indicate that an abnormal system event has occurred, including: power failure, improper line voltage supply, collector temperature rise above -40° C, service vacuum pump (after 1000 hours of vacuum use), and moisture in collector. Pressing the Menu Switch displays the alarm message on the LCD.
- LED vacuum and temperature “waves” for at-a-glance display of relative system vacuum and collector temperature.
- ❖ Moisture sensor that prevents refrigeration or vacuum start-up when moisture is detected in the collector chamber area.
- Vacuum control valve that maintains setpoint vacuum level.
- ❖ Vacuum break valve that bleeds air into the system when power to the freeze dryer or vacuum pump is shut off. If a power outage less than approximately 5 minutes occurs, the freeze dryer will restart and the refrigeration and vacuum system will resume operation once power is restored. If the power failure is more than approximately 5 minutes and the collector warms above safe limits, the freeze dryer will not automatically restart.
- Rear-mounted RS-232 port to transmit data to a user-supplied computer. Transmission intervals may be user-configured for 10, 30, 60, 300 or 600 seconds.
- Automatic start-up switch for collector cool-down and vacuum pull-down with manual override switches.
- Side-mounted, retractable, 9" collector drain hose.
- 3" diameter port for connection of drying accessories (sold separately).
- Side-mounted power switch and rear-mounted electrical receptacle (for vacuum pump connection).
- 3/4" OD vacuum connection, three feet of 3/4" ID vacuum hose and two clamps.
- Overall dimensions: 31.8" w x 28.1" d x 14.5" h (80.8 cm x 71.4 cm x 36.8 cm).

Models conform to the following standards:

- UL Standard 61010A-1 (60 Hz models).
- CAN/CSA C22.2 No. 1010.1 (60 Hz models).
- CE Conformity marking (220/240 volts, 50 Hz models).

Options include:

- Teflon-coated collector coil and chamber for processes involving corrosive compounds.
- Stoppering Tray Dryer, 32.0" w x 24.6" d x 27.1" h (81.3 cm x 62.4 cm x 68.8 cm). Overall dimensions with Stoppering Tray Dryer: 32.0" w x 31.1" d x 40.6" h (81.3 cm x 79.0 cm x 103.1 cm). See specifications on pages 30-32.
- Domestic or international electrical configuration. Models wired for 115 volts, 60 Hz include a 3-wire cord with 20 amp NEMA 5-20P plug. Models wired for 220/240 volts, 50 Hz or 208/230 volts, 60 Hz include a 3-wire cord with 20 amp NEMA 6-20P plug.



FreeZone 6 Liter Benchtop Freeze Dry System 7752020, Variable Height Bench 8075000, 20-Port Manifold with Support Shelves 7522500 and miscellaneous glassware.

All models require (not included):

- Vacuum pump with a displacement of at least 144 liters per minute, 0.002 mBar ultimate pressure, 15 amp NEMA 5-15P plug (115 volt models) or reverse IEC plug (220/240 or 208/230 volt models), and fitting suitable for 3/4" ID vacuum hose. See pages 44-46.
- Drying accessory (except models with Stoppering Tray Dryer). See pages 34-42.
- Freeze dry glassware if not bulk freeze drying. See pages 48-51.

Catalog Number	Electrical Requirements (without vacuum pump)	Teflon-Coated Collector Coil & Chamber	Stoppering Tray Dryer	Shipping Weight
7752020	115 volts, 60 Hz, 9.0 A			150 lbs. (68 kg)
7752021	115 volts, 60 Hz, 9.0 A	•		150 lbs. (68 kg)
7752040	208/230 volts, 60 Hz, 3.0 A			150 lbs. (68 kg)
7752041	208/230 volts, 60 Hz, 3.0 A	•		150 lbs. (68 kg)
7758020	115 volts, 60 Hz, 9.0 A 115 volts, 60 Hz, 16.0 A [†]		•	572 lbs. (259 kg) Shipped in 2 cartons
7758021	115 volts, 60 Hz, 9.0 A 115 volts, 60 Hz, 16.0 A [†]	•	•	572 lbs. (259 kg) Shipped in 2 cartons
7758040	208/230 volts, 60 Hz, 3.0 A 230 volts, 60 Hz, 9.0 A [†]		•	572 lbs. (259 kg) Shipped in 2 cartons
7758041	208/230 volts, 60 Hz, 3.0 A 230 volts, 60 Hz, 9.0 A [†]	•	•	572 lbs. (259 kg) Shipped in 2 cartons
7752030*	220/240 volts, 50 Hz, 3.0 A			150 lbs. (68 kg)
7752031*	220/240 volts, 50 Hz, 3.0 A	•		150 lbs. (68 kg)
7758030*	220/240 volts, 50 Hz, 3.0 A 230 volts, 50 Hz, 9.0 A [†]		•	572 lbs. (259 kg) Shipped in 2 cartons
7758031*	220/240 volts, 50 Hz, 3.0 A 230 volts, 50 Hz, 9.0 A [†]	•	•	572 lbs. (259 kg) Shipped in 2 cartons

*International electrical configuration † Electrical requirements of the Stoppering Tray Dryer

❖ Exclusive feature



FreeZone® 6, 12 & 18 Liter Freeze Dry Systems

FEATURES & BENEFITS



Optional built-in vacuum drying chamber holds small samples, either in bulk or in small containers such as vials. It may be used in conjunction with other drying accessories mounted on the attachment port or independently. For larger samples or higher volumes of samples, a separate drying accessory is required (sold separately). Its 50-watt heater is microprocessor-controlled from the front panel to +60° C (+140° F). (The chamber is not cooled. The only cooling is from the frozen sample.)

Rear-mounted electrical receptacle allows connection of the vacuum pump (pump sold separately).

Attachment port makes connection of accessories easy. Select from accessory drying chambers and manifolds (sold separately).

Stainless steel collector chamber resists corrosion from aqueous samples. Models are available with Teflon-coated collector coil and chamber for additional corrosion resistance.

Vacuum and temperature graphs display relative system vacuum and collector temperature. Amber LED “waves” illuminate when vacuum and temperature levels are out of range for adding samples. Green LED lights indicate that conditions are right to add samples.

✦ **LCD** displays system set-up and operating parameters and alarm messages.

Easy-to-follow operating instructions are printed on the left-hand side.

Automatic start-up is quick and easy to use. Pressing one button initiates the collector cool-down and vacuum pull-down sequence. Or, manually override this feature at any time using the separate switches for manual refrigeration and vacuum.

Collector drain hose is accessible from the front for convenient defrost. It extends about nine inches and retracts within the cabinet when not in use.



CE marking. All 220/240 volt, 50 Hz models conform to the CE (European Community) requirements for electrical safety and electromagnetic compatibility.



ETL listed. Models for operation on 115 volts, 60 Hz or 208/230 volts, 60 Hz carry the ETL mark signifying they are certified to UL Standard 61010A-1 and CAN/CSA C22.2 No. 1010.1.

✦ *Exclusive feature*

CFC-free refrigeration system ensures rapid, environmentally-safe cooling. The condensing module cools the collector coil to -50° C (-58° F), ideal for freeze drying aqueous samples. The system uses a non-flammable refrigerant that contains no ozone-damaging chlorofluorocarbons (CFCs).

Factory wired. All models include a 3-wire cord with 20 amp NEMA plug.

Optional purge valve isolates the vacuum pump from the freeze dry system. The pump starts and warms the oil, while the collector cools, before pulling vacuum on the system. Pump life may be extended by purging small amounts of contaminants from the vacuum pump oil. Green indicator lights when the purge valve is closed.

Optional built-in shell freezer (6 liter models only) permits sample preparation while other samples lyophilize. The bath has two rollers to rotate flasks up to 1200 ml in size in heat transfer solution. The bath's separate CFC-free refrigeration system ensures rapid pre-freezing. A drain hose is accessible from the front for easy disposal of the heat transfer solution.

Rear-mounted RS-232 port may be used to transmit data to a user-supplied computer. The time between data transmissions may be set to occur at 10, 30, 60, 300 or 600 second intervals.

Hot gas defrost. Hot gas from the compressor is circulated through the collector coil and automatically shuts off when the refrigerant reaches +65° C (+149° F).

✦ **Red alarm light** flashes and beeper sounds to indicate that an abnormal system event has occurred. Pressing the Menu Switch displays the alarm message on the LCD.

✦ **Moisture sensor** protects the vacuum pump by preventing refrigeration or vacuum start-up when moisture is detected in the collector chamber area.

✦ **Durable console cabinet.** Cabinet, mounted on 3" diameter casters, is epoxy-coated steel with a removable brushed stainless steel front panel. The roomy interior accommodates a vacuum pump (pump sold separately).

Vacuum control valve maintains setpoint vacuum level to speed the freeze drying process.

✦ **Vacuum break valve** protects the system from oil back-streaming by bleeding air into the system when power to the freeze dryer or vacuum pump is shut off. If a brief power outage occurs (< approximately 5 minutes), the freeze dryer will restart and the refrigeration and vacuum system will resume operation once power is restored. If the power failure is long (> approximately 5 minutes) and the collector warms above safe limits, the freeze dryer will not automatically restart, which prevents melted sample from being drawn into the collector and liquid from harming the vacuum pump.



FreeZone® 6 Liter Freeze Dry Systems

SPECIFICATIONS

All models feature:

- Upright stainless steel collector coil capable of removing 4 liters of water in 24 hours and holding 6 liters of ice before defrosting.
- 3/4 hp CFC-free refrigeration system to cool collector to -50° C (-58° F).
- Clear acrylic chamber lid, 3/4" thick, with neoprene gasket.
- ※ Brushed stainless steel and glacier white, epoxy-coated steel exterior with blue accents.
- ※ LCD that displays system operating parameters, set-up parameters and alarm messages. It may be user-configured to display vacuum in mBar, Pa or Torr and temperature in ° F or ° C. It also displays total number of hours of refrigeration system operation and time since the refrigeration system was serviced and the total number of hours of vacuum pump operation and time since the vacuum pump was serviced (in hours).
- Red alarm light that flashes and beeper that sounds to indicate that an abnormal system event has occurred, including: power failure, improper line voltage supply, collector temperature rise above -40° C, service vacuum pump (after 1000 hours of vacuum use), and moisture in collector. Pressing the Menu Switch displays the alarm message on the LCD.
- LED vacuum and temperature "waves" for at-a-glance display of relative system vacuum and collector temperature.
- ※ Moisture sensor that prevents refrigeration or vacuum start-up when moisture is detected in the collector chamber area.
- Vacuum control valve that maintains setpoint vacuum level.
- ※ Vacuum break valve that bleeds air into the system when power to the freeze dryer or vacuum pump is shut off. If a power outage less than approximately 5 minutes occurs, the freeze dryer will restart and the refrigeration and vacuum system will resume operation once power is restored. If the power failure is more than approximately 5 minutes and the collector warms above safe limits, the freeze dryer will not automatically restart.
- Rear-mounted RS-232 port to transmit data to a user-supplied computer. Transmission intervals may be user-configured for 10, 30, 60, 300 or 600 seconds.
- Automatic start-up switch for collector cool-down and vacuum pull-down with manual override switches.
- Hot gas defrost and switch.
- Front-mounted, retractable, 9" collector drain hose.
- 3" diameter stainless steel port for connection of drying accessories (sold separately).
- Side-mounted power switch and rear-mounted electrical receptacle (for vacuum pump connection).
- 3" diameter casters.
- 3/4" OD vacuum connection, three feet of 3/4" ID vacuum hose and two clamps.
- Overall dimensions: 32.2" w x 28.0" d x 36.3" h (81.8 cm x 71.1 cm x 92.1 cm).
- Usable interior space: 15.0" w x 24.5" d x 22.0" h (38.1 cm x 62.2 cm x 55.9 cm). Usable interior space on models with built-in shell freezer: 11.5" w x 24.5" d x 12.0" h (29.2 cm x 62.2 cm x 30.5 cm).

Models conform to the following standards:

- UL Standard 61010A-1 (60 Hz models).
- CAN/CSA C22.2 No. 1010.1 (60 Hz models).
- CE Conformity marking (220/240 volts, 50 Hz models).

Options include:

- Teflon-coated collector coil and chamber for processes involving corrosive compounds.



FreeZone 6 Liter Freeze Dry System with built-in shell freezer 7753522, 16-Port Drying Chamber 7522900 and miscellaneous glassware.

- Purge valve with switch for isolating the vacuum pump from the freeze dry system.
- Built-in stainless steel mini vacuum drying chamber, 5.1" w x 13.0" d x 2.5" h (12.9 cm x 33.0 cm x 6.4 cm), that includes 50-watt heater with microprocessor control to +60° C (+140° F), 3/4" thick clear acrylic lid and neoprene gasket. (Chamber is not cooled. The only cooling is from the frozen sample.)
- Built-in shell freezer with stainless steel bath, 5.5" w x 12.5" d x 7.5" h (30.5 cm x 14.0 cm x 19.0 cm), that includes 1/3 hp CFC-free refrigeration system with microprocessor control to -40° C (-40° F), 3/4" thick high-density polyethylene lid, neoprene gasket and drain hose.
- Stopping Tray Dryer, 32.0" w x 24.6" d x 27.1" h (81.3 cm x 62.4 cm x 68.8 cm). Overall dimensions with Stopping Tray Dryer: 32.0" w x 31.0" d x 63.4" h (81.3 cm x 78.7 cm x 160.9 cm). See specifications on pages 34-36.
- Domestic or international electrical configuration. Models wired for 115 volts, 60 Hz include a 3-wire cord with 20 amp NEMA 5-20P plug. Models wired for 220/240 volts, 50 Hz or 208/230 volts, 60 Hz include a 3-wire cord with 20 amp NEMA 6-20P plug.

All models require (not included):

- Vacuum pump with a displacement of at least 144 liters per minute, 0.002 mBar ultimate pressure, 15 amp NEMA 5-15P plug (115 volt models) or reverse IEC plug (220/240 or 208/230 volt models), and fitting suitable for 3/4" ID vacuum hose. See pages 44-46.
- Drying accessory (except for models with Stopping Tray Dryer). See pages 34-42.
- Freeze dry glassware if not bulk freeze drying. See pages 48-51.

See ordering information on page 24.

※ Exclusive feature



FreeZone® 12 Liter Freeze Dry Systems

SPECIFICATIONS

All models feature:

- Upright stainless steel collector coil capable of removing 8 liters of water in 24 hours and holding 12 liters of ice before defrosting.
- 1 hp CFC-free refrigeration system to cool collector to -50° C (-58° F).
- Clear acrylic chamber lid, 3/4" thick, with neoprene gasket.
- ✳ Brushed stainless steel and glacier white epoxy-coated steel exterior with blue accents.
- ✳ LCD that displays system operating parameters, set-up parameters and alarm messages. It may be user-configured to display vacuum in mBar, Pa or Torr and temperature in ° F or ° C. It also displays total number of hours of refrigeration system operation and time since the refrigeration system was serviced and the total number of hours of vacuum pump operation and time since the vacuum pump was serviced (in hours).
- Red alarm light that flashes and beeper that sounds to indicate that an abnormal system event has occurred, including: power failure, improper line voltage supply, collector temperature rise above -40° C, service vacuum pump (after 1000 hours of vacuum use), and moisture in collector. Pressing the Menu Switch displays the alarm message on the LCD.
- LED vacuum and temperature "waves" for at-a-glance display of relative system vacuum and collector temperature.
- ✳ Moisture sensor that prevents refrigeration or vacuum start-up when moisture is detected in the collector chamber area.
- Vacuum control valve that maintains setpoint vacuum level.
- ✳ Vacuum break valve that bleeds air into the system when power to the freeze dryer or vacuum pump is shut off. If a power outage less than approximately 5 minutes occurs, the freeze dryer will restart and the refrigeration and vacuum system will resume operation once power is restored. If the power failure is more than approximately 5 minutes and the collector warms above safe limits, the freeze dryer will not automatically restart.
- Rear-mounted RS-232 port to transmit data to a user-supplied computer. Transmission intervals may be user-configured for 10, 30, 60, 300 or 600 seconds.
- Automatic start-up switch for collector cool-down and vacuum pull-down with manual override switches.
- Hot gas defrost and switch.
- Front-mounted, retractable, 9" collector drain hose.
- 3" diameter stainless steel port for connection of drying accessories (sold separately).
- Side-mounted power switch and rear-mounted electrical receptacle (for vacuum pump connection).
- 3" diameter casters.
- 3-wire cord with 20 amp NEMA 6-20P plug.
- 3/4" OD vacuum connection, three feet of 3/4" ID vacuum hose and two clamps.
- Overall dimensions: 32.2" w x 28.0" d x 36.3" h (84.8 cm x 71.1 cm x 92.1 cm).
- Usable interior space: 14.0" w x 24.5" d x 22.0" h (35.6 cm x 62.2 cm x 55.9 cm).

Models conform to the following standards:

- UL Standard 61010A-1 (208/230 volts, 60 Hz models).
- CAN/CSA C22.2 No. 1010.1 (208/230 volts, 60 Hz models).
- CE Conformity marking (220/240 volts, 50 Hz models).

Options include:

- Teflon-coated collector coil and chamber for processes involving corrosive compounds.



FreeZone 12 Liter Freeze Dry System with Stoppering Tray Dryer 7759040 and Serum Bottles 7573210.

- Purge valve with switch for isolating the vacuum pump from the freeze dry system.
- Built-in stainless steel mini vacuum drying chamber, 5.1" w x 13.0" d x 2.5" h (12.9 cm x 33.0 cm x 6.4 cm), that includes 50-watt heater with microprocessor control to +60° C (+140° F), 3/4" thick clear acrylic lid and neoprene gasket. (Chamber is not cooled. The only cooling is from the frozen sample.)
- Stoppering Tray Dryer, 32.0" w x 24.6" d x 27.1" h (81.3 cm x 62.4 cm x 68.8 cm). Overall dimensions with Stoppering Tray Dryer: 32.0" w x 31.0" d x 63.4" h (81.3 cm x 78.7 cm x 160.9 cm). See specifications on pages 30-32.
- Domestic or international electrical configuration.

All models require (not included):

- Vacuum pump with a displacement of at least 144 liters per minute, 0.002 mBar ultimate pressure, reverse IEC plug and fitting suitable for 3/4" ID vacuum hose. See pages 44-46.
 - Drying accessory (except models with Stoppering Tray Dryer). See pages 34-42.
 - Freeze dry glassware if not bulk freeze drying. See pages 48-51.
- See ordering information on page 25.

✳ Exclusive feature



FreeZone® 18 Liter Freeze Dry Systems

SPECIFICATIONS

All models feature:

- Upright stainless steel collector coil capable of removing 10 liters of water in 24 hours and holding 18 liters of ice before defrosting.
- 1-1/2 hp CFC-free refrigeration system to cool collector to -50° C (-58° F).
- Clear acrylic chamber lid, 3/4" thick, with neoprene gasket.
- ❖ Brushed stainless steel and glacier white, epoxy-coated steel exterior with blue accents.
- ❖ LCD that displays system operating parameters, set-up parameters and alarm messages. It may be user-configured to display vacuum in mBar, Pa or Torr and temperature in ° F or ° C. It also displays total number of hours of refrigeration system operation and time since the refrigeration system was serviced and the total number of hours of vacuum pump operation and time since the vacuum pump was serviced (in hours).
- Red alarm light that flashes and beeper that sounds to indicate that an abnormal system event has occurred, including: power failure, improper line voltage supply, collector temperature rise above -40° C, service vacuum pump (after 1000 hours of vacuum use), and moisture in collector. Pressing the Menu Switch displays the alarm message on the LCD.
- LED vacuum and temperature "waves" for at-a-glance display of relative system vacuum and collector temperature.
- ❖ Moisture sensor that prevents refrigeration or vacuum start-up when moisture is detected in the collector chamber area.
- Vacuum control valve that maintains setpoint vacuum level.
- ❖ Vacuum break valve that bleeds air into the system when power to the freeze dryer or vacuum pump is shut off. If a power outage less than approximately 5 minutes occurs, the freeze dryer will restart and the refrigeration and vacuum system will resume operation once power is restored. If the power failure is more than approximately 5 minutes and the collector warms above safe limits, the freeze dryer will not automatically restart.
- Rear-mounted RS-232 port to transmit data to a user-supplied computer. Transmission intervals may be user-configured for 10, 30, 60, 300 or 600 seconds.
- Automatic start-up switch for collector cool-down and vacuum pull-down with manual override switches.
- Hot gas defrost and switch.
- Front-mounted, retractable, 9" collector drain hose.
- 3" diameter stainless steel port for connection of drying accessories (sold separately).
- Side-mounted power switch and rear-mounted electrical receptacle (for vacuum pump connection).
- 3" diameter casters.
- 3-wire cord with 20 amp NEMA 6-20P plug.
- 3/4" OD vacuum connection, three feet of 3/4" ID vacuum hose and two clamps.
- Overall dimensions: 32.2" w x 28.0" d x 36.3" h (84.8 cm x 71.1 cm x 92.1 cm).
- Usable interior space: 14.0" w x 24.5" d x 22.0" h (35.6 cm x 62.2 cm x 55.9 cm).

Models conform to the following standards:

- UL Standard 61010A-1 (60 Hz models).
- CAN/CSA C22.2 No. 1010.1 (60 Hz models).
- CE Conformity marking (220/240 volts, 50 Hz models).



FreeZone 18 Liter Freeze Dry System 7755040, 48-Port Manifold 7868500 and miscellaneous glassware.

Options include:

- Teflon-coated collector coil and chamber for processes involving corrosive compounds.
- Purge valve with switch for isolating the vacuum pump from the freeze dry system.
- Built-in stainless steel mini vacuum drying chamber, 5.1" w x 13.0" d x 2.5" h (12.9 cm x 33.0 cm x 6.4 cm), that includes 50-watt heater with microprocessor control to +60° C (+140° F), 3/4" thick clear acrylic lid and neoprene gasket. (Chamber is not cooled. The only cooling is from the frozen sample.)
- Domestic or international electrical configuration.

All models require (not included):

- Vacuum pump with a displacement of at least 144 liters per minute, 0.002 mBar ultimate pressure, reverse IEC plug and fitting suitable for 3/4" ID vacuum hose. See pages 44-46.
- Drying accessory. See pages 34-42.
- Freeze dry glassware if not bulk freeze drying. See pages 48-51.

See ordering information on page 25.

❖ Exclusive feature



FreeZone® 6, 12 & 18 Liter Freeze Dry Systems

ORDERING INFORMATION

FreeZone® 6 Liter Freeze Dry Systems

Catalog Number	Electrical Requirements (without vacuum pump)	OPTIONS INCLUDED				Shipping Weight
		Teflon-Coated Collector Coil & Chamber	Purge Valve	Mini Chamber	Shell Freezer	
7753020	115 volts, 60 Hz, 9.0 A					254 lbs. (115 kg)
7753021	115 volts, 60 Hz, 9.0 A	•				254 lbs. (115 kg)
7753022	115 volts, 60 Hz, 9.0 A		•			257 lbs. (117 kg)
7753024	115 volts, 60 Hz, 9.0 A	•	•			257 lbs. (117 kg)
7753026	115 volts, 60 Hz, 9.0 A		•	•		272 lbs. (123 kg)
7753027	115 volts, 60 Hz, 9.0 A	•	•	•		272 lbs. (123 kg)
7753040	208/230 volts, 60 Hz, 3.0 A					254 lbs. (115 kg)
7753041	208/230 volts, 60 Hz, 3.0 A	•				254 lbs. (115 kg)
7753042	208/230 volts, 60 Hz, 3.0 A		•			257 lbs. (117 kg)
7753044	208/230 volts, 60 Hz, 3.0 A	•	•			257 lbs. (117 kg)
7753046	208/230 volts, 60 Hz, 3.0 A		•	•		272 lbs. (123 kg)
7753047	208/230 volts, 60 Hz, 3.0 A	•	•	•		272 lbs. (123 kg)
7753522	115 volts, 60 Hz, 13.0 A		•		•	324 lbs. (147 kg)
7753524	115 volts, 60 Hz, 13.0 A	•	•		•	324 lbs. (147 kg)
7753542	208/230 volts, 60 Hz, 5.5 A		•		•	324 lbs. (147 kg)
7753544	208/230 volts, 60 Hz, 5.5 A	•	•		•	324 lbs. (147 kg)
7753030*	220/240 volts, 50 Hz, 3.0 A					254 lbs. (115 kg)
7753031*	220/240 volts, 50 Hz, 3.0 A	•				254 lbs. (115 kg)
7753032*	220/240 volts, 50 Hz, 3.0 A		•			257 lbs. (117 kg)
7753034*	220/240 volts, 50 Hz, 3.0 A	•	•			257 lbs. (117 kg)
7753036*	220/240 volts, 50 Hz, 3.0 A		•	•		272 lbs. (123 kg)
7753037*	220/240 volts, 50 Hz, 3.0 A	•	•	•		272 lbs. (123 kg)
7753532*	220/240 volts, 50 Hz, 5.5 A		•		•	324 lbs. (147 kg)
7753534*	220/240 volts, 50 Hz, 5.5 A	•	•		•	324 lbs. (147 kg)

FreeZone® 6 Liter Freeze Dry Systems with Stopping Tray Dryers

Catalog Number	Electrical Requirements (without vacuum pump)	OPTIONS INCLUDED			Shipping Weight
		Teflon-Coated Collector Coil & Chamber	Purge Valve	Stopping Tray Dryer	
7758520	115 volts, 60 Hz, 9.0 A 115 volts, 60 Hz, 16.0 A [†]			•	676 lbs. (307 kg) Shipped in 2 cartons
7758521	115 volts, 60 Hz, 9.0 A 115 volts, 60 Hz, 16.0 A [†]	•		•	676 lbs. (307 kg) Shipped in 2 cartons
7758522	115 volts, 60 Hz, 9.0 A 115 volts, 60 Hz, 16.0 A [†]		•	•	679 lbs. (308 kg) Shipped in 2 cartons
7758524	115 volts, 60 Hz, 9.0 A 115 volts, 60 Hz, 16.0 A [†]	•	•	•	679 lbs. (308 kg) Shipped in 2 cartons
7758540	208/230 volts, 60 Hz, 3.0 A 208/230 volts, 60 Hz, 9.0 A [†]			•	676 lbs. (307 kg) Shipped in 2 cartons
7758541	208/230 volts, 60 Hz, 3.0 A 208/230 volts, 60 Hz, 9.0 A [†]	•		•	676 lbs. (307 kg) Shipped in 2 cartons
7758542	208/230 volts, 60 Hz, 3.0 A 208/230 volts, 60 Hz, 9.0 A [†]		•	•	679 lbs. (308 kg) Shipped in 2 cartons
7758544	208/230 volts, 60 Hz, 3.0 A 208/230 volts, 60 Hz, 9.0 A [†]	•	•	•	679 lbs. (308 kg) Shipped in 2 cartons
7758530*	220/240 volts, 50 Hz, 3.0 A 220/240 volts, 50 Hz, 9.0 A [†]			•	676 lbs. (307 kg) Shipped in 2 cartons
7758531*	220/240 volts, 50 Hz, 3.0 A 220/240 volts, 50 Hz, 9.0 A [†]	•		•	676 lbs. (307 kg) Shipped in 2 cartons
7758532*	220/240 volts, 50 Hz, 3.0 A 220/240 volts, 50 Hz, 9.0 A [†]		•	•	679 lbs. (308 kg) Shipped in 2 cartons
7758534*	220/240 volts, 50 Hz, 3.0 A 220/240 volts, 50 Hz, 9.0 A [†]	•	•	•	679 lbs. (308 kg) Shipped in 2 cartons

*International electrical configuration

[†]Electrical requirements of Stopping Tray Dryer



FreeZone® 6, 12 & 18 Liter Freeze Dry Systems

ORDERING INFORMATION

FreeZone® 12 Liter Freeze Dry Systems

OPTIONS INCLUDED

Catalog Number	Electrical Requirements (without vacuum pump)	Teflon-Coated Collector Coil & Chamber	Purge Valve	Mini Chamber	Shipping Weight
7754040	208/230 volts, 60 Hz, 5.0 A				275 lbs. (125 kg)
7754041	208/230 volts, 60 Hz, 5.0 A	•			275 lbs. (125 kg)
7754042	208/230 volts, 60 Hz, 5.0 A		•		278 lbs. (126 kg)
7754044	208/230 volts, 60 Hz, 5.0 A	•	•		278 lbs. (126 kg)
7754046	208/230 volts, 60 Hz, 5.0 A		•	•	293 lbs. (133 kg)
7754047	208/230 volts, 60 Hz, 5.0 A	•	•	•	293 lbs. (133 kg)
7754030*	220/240 volts, 50 Hz, 4.5 A				275 lbs. (125 kg)
7754031*	220/240 volts, 50 Hz, 4.5 A	•			275 lbs. (125 kg)
7754032*	220/240 volts, 50 Hz, 4.5 A		•		278 lbs. (126 kg)
7754034*	220/240 volts, 50 Hz, 4.5 A	•	•		278 lbs. (126 kg)
7754036*	220/240 volts, 50 Hz, 4.5 A		•	•	293 lbs. (133 kg)
7754037*	220/240 volts, 50 Hz, 4.5 A	•	•	•	293 lbs. (133 kg)

FreeZone® 12 Liter Freeze Dry Systems with Stopping Tray Dryers

OPTIONS INCLUDED

Catalog Number	Electrical Requirements (without vacuum pump)	Teflon-Coated Collector Coil & Chamber	Purge Valve	Stopping Tray Dryer	Shipping Weight
7759040	208/230 volts, 60 Hz, 5.0 A 208/230 volts, 60 Hz, 9.0 A [†]			•	697 lbs. (316 kg) Shipped in 2 cartons
7759041	208/230 volts, 60 Hz, 5.0 A 208/230 volts, 60 Hz, 9.0 A [†]	•		•	697 lbs. (316 kg) Shipped in 2 cartons
7759042	208/230 volts, 60 Hz, 5.0 A 208/230 volts, 60 Hz, 9.0 A [†]		•	•	700 lbs. (318 kg) Shipped in 2 cartons
7759044	208/230 volts, 60 Hz, 5.0 A 208/230 volts, 60 Hz, 9.0 A [†]	•	•	•	700 lbs. (318 kg) Shipped in 2 cartons
7759030*	220/240 volts, 50 Hz, 4.5 A 220/240 volts, 50 Hz, 9.0 A [†]			•	697 lbs. (316 kg) Shipped in 2 cartons
7759031*	220/240 volts, 50 Hz, 4.5 A 220/240 volts, 50 Hz, 9.0 A [†]	•		•	697 lbs. (316 kg) Shipped in 2 cartons
7759032*	220/240 volts, 50 Hz, 4.5 A 220/240 volts, 50 Hz, 9.0 A [†]		•	•	700 lbs. (318 kg) Shipped in 2 cartons
7759034*	220/240 volts, 50 Hz, 4.5 A 220/240 volts, 50 Hz, 9.0 A [†]	•	•	•	700 lbs. (318 kg) Shipped in 2 cartons

FreeZone® 18 Liter Freeze Dry Systems

OPTIONS INCLUDED

Catalog Number	Electrical Requirements (without vacuum pump)	Teflon-Coated Collector Coil & Chamber	Purge Valve	Mini Chamber	Shipping Weight
7755040	208/230 volts, 60 Hz, 5.5 A				285 lbs. (129 kg)
7755041	208/230 volts, 60 Hz, 5.5 A	•			285 lbs. (129 kg)
7755042	208/230 volts, 60 Hz, 5.5 A		•		288 lbs. (131 kg)
7755044	208/230 volts, 60 Hz, 5.5 A	•	•		288 lbs. (131 kg)
7755046	208/230 volts, 60 Hz, 5.5 A		•	•	303 lbs. (137 kg)
7755047	208/230 volts, 60 Hz, 5.5 A	•	•	•	303 lbs. (137 kg)
7755030*	220/240 volts, 50 Hz, 5.5 A				285 lbs. (129 kg)
7755031*	220/240 volts, 50 Hz, 5.5 A	•			285 lbs. (129 kg)
7755032*	220/240 volts, 50 Hz, 5.5 A		•		288 lbs. (131 kg)
7755034*	220/240 volts, 50 Hz, 5.5 A	•	•		288 lbs. (131 kg)
7755036*	220/240 volts, 50 Hz, 5.5 A		•	•	303 lbs. (137 kg)
7755037*	220/240 volts, 50 Hz, 5.5 A	•	•	•	303 lbs. (137 kg)

*International electrical configuration

[†]Electrical requirements of Stopping Tray Dryer



FreeZone® Plus™ 6 & 12 Liter Cascade Freeze Dry Systems

FEATURES & BENEFITS

Optional built-in vacuum drying chamber holds small samples, either in bulk or in small containers such as vials. It may be used in conjunction with other drying accessories mounted on the attachment port or independently. For larger samples or higher volumes of samples, a separate drying accessory is required (sold separately). Its 50-watt heater is microprocessor-controlled from the front panel to +60° C (+140° F). (The chamber is not cooled. The only cooling is from the frozen sample.)

Easy-to-follow operating instructions are printed on the left-hand side.

Automatic start-up is quick and easy to use. Pressing one button initiates the collector cool-down and vacuum pull-down sequence. Or, manually override this feature at any time using the separate switches for manual refrigeration and vacuum.

Collector drain hose is accessible from the front for convenient defrost. It extends about 9 inches and retracts within the cabinet when not in use.

Factory wired. All models require a 3-wire cord with 20 amp NEMA plug.



CE marking. All 220/240 volt, 50 Hz models conform to the CE (European Community) requirements for electrical safety and electromagnetic compatibility.



ETL listed. Models for operation on 115 volts, 60 Hz or 208/230 volts, 60 Hz carry the ETL mark signifying they are certified to UL Standard 61010A-1 and CAN/CSA C22.2 No. 1010.1.

❖ **LCD** displays system set-up and operating parameters and alarm messages.

Attachment port makes connection of accessories easy. Select from accessory drying chambers and manifolds (sold separately).

Upright, stainless steel collector chamber speeds and simplifies defrost. Models are available with Teflon-coated collector coil and chamber for additional corrosion resistance.

Vacuum and temperature graphs display relative system vacuum and collector temperature. Amber LED "waves" illuminate when vacuum and temperature levels are out of range for adding samples. Green LED lights indicate that conditions are right to add samples.

❖ **Red alarm light** flashes and beeper sounds to indicate that an abnormal system event has occurred. Pressing the Menu Switch displays the alarm message on the LCD.

❖ **Moisture sensor** protects the vacuum pump by preventing refrigeration or vacuum start-up when moisture is detected in the collector chamber area.

Vacuum control valve maintains setpoint vacuum level to speed the freeze drying process.

CFC/HCFC-free refrigeration systems ensure rapid, environmentally-safe cooling. Two refrigeration systems, used in series, cool the stainless steel collector to **-84° C (-119° F)** making this system ideal for freeze drying samples with low eutectic points. The systems use a non-flammable refrigerant that contains no ozone-damaging chlorofluorocarbons (CFCs) or hydrochlorofluorocarbons (HCFCs).

Rear-mounted RS-232 port may be used to transmit data to a user-supplied computer. The time between data transmissions may be set to occur at 10, 30, 60, 300 or 600 second intervals.

Rear-mounted electrical receptacle allows connection of the vacuum pump (pump sold separately).

Optional purge valve isolates the vacuum pump from the freeze dry system. The pump starts and warms the oil, while the collector cools, before pulling vacuum on the system. Pump life may be extended by purging small amounts of contaminants from the vacuum pump oil. Green indicator lights when the purge valve is closed.

❖ **Durable console cabinet.** Cabinet, mounted on 3" diameter casters, is epoxy-coated steel with a removable brushed stainless steel front panel. The roomy interior accommodates a vacuum pump (pump sold separately).

Hot gas defrost. Hot gas from the compressor is circulated through the collector coil and automatically shuts off when the refrigerant reaches +65° C (+149° F).

❖ **Vacuum break valve** protects the system from oil back-streaming by bleeding air into the system when power to the freeze dryer or vacuum pump is shut off. If a brief power outage occurs (< approximately 5 minutes), the freeze dryer will restart and the refrigeration and vacuum system will resume operation once power is restored. If the power failure is long (> approximately 5 minutes) and the collector warms above safe limits, the freeze dryer will not automatically restart, which prevents melted sample from being drawn into the collector and liquid from harming the vacuum pump.

Stainless steel baffle maximizes ice loading capabilities by evenly distributing collected ice over the entire collector coil.

❖ Exclusive feature



FreeZone® Plus™ 6 Liter Cascade Freeze Dry Systems

SPECIFICATIONS

All models feature:

- Upright stainless steel collector coil and chamber with stainless steel baffle capable of removing 2 liters of water in 24 hours and holding 6 liters of ice before defrosting.
- Two 1/3 hp CFC-free and HCFC-free refrigeration systems, used in series, to cool collector to **-84° C (-119° F)**.
- Clear acrylic chamber lid, 3/4" thick, with neoprene gasket.
- ❖ Brushed stainless steel and glacier white, epoxy-coated steel exterior with blue accents.
- ❖ LCD that displays system operating parameters, set-up parameters and alarm messages. It may be user-configured to display vacuum in mBar, Pa or Torr and temperature in ° F or ° C. It also displays total number of hours of refrigeration system operation and time since the refrigeration was serviced and the total number of hours of vacuum pump operation and time since the vacuum pump was serviced (in hours).
- Red alarm light that flashes and beeper that sounds to indicate that an abnormal system event has occurred, including: power failure, improper line voltage supply, collector temperature rise above -40° C, service vacuum pump (after 1000 hours of vacuum use), and moisture in collector. Pressing the Menu Switch displays the alarm message on the LCD.
- LED vacuum and temperature "waves" for at-a-glance display of relative system vacuum and collector temperature.
- ❖ Moisture sensor that prevents refrigeration or vacuum start-up when moisture is detected in the collector chamber area.
- Vacuum control valve that maintains setpoint vacuum level.
- ❖ Vacuum break valve that bleeds air into the system when power to the freeze dryer or vacuum pump is shut off. If a power outage less than approximately 5 minutes occurs, the freeze dryer will restart and the refrigeration and vacuum system will resume operation once power is restored. If the power failure is more than approximately 5 minutes and the collector warms above safe limits, the freeze dryer will not automatically restart.
- Rear-mounted RS-232 port to transmit data to a user-supplied computer. Transmission intervals may be user-configured for 10, 30, 60, 300 or 600 seconds.
- Automatic start-up switch for collector cool-down and vacuum pull-down with manual override switches.
- Hot gas defrost and switch.
- Front-mounted, retractable, 9" collector drain hose.
- 3" diameter stainless steel port for connection of drying accessories (sold separately).
- Side-mounted power switch and rear-mounted electrical receptacle (for vacuum pump connection).
- 3" diameter casters.
- 3/4" OD vacuum connection, three feet of 3/4" ID vacuum hose and two clamps.
- Overall dimensions: 32.2" w x 28.0" d x 36.3" h (84.8 cm x 71.1 cm x 92.1 cm).
- Usable interior space: 14.0" w x 24.5" d x 22.0" h (35.6 cm x 62.2 cm x 55.9 cm)

Models conform to the following standards:

- UL Standard 61010A-1 (60 Hz models).
- CAN/CSA C22.2 No. 1010.1 (60 Hz models).
- CE Conformity marking (220/240 volts, 50 Hz models).



FreeZone Plus 6 Liter Cascade Freeze Dry System 7934020, FreeZone Stopping Tray Dryer 7948020, 6-Port Tray Dryer Manifold 7726500 and miscellaneous glassware.

Options include:

- Teflon-coated collector coil and chamber for processes involving corrosive compounds.
- Purge valve with switch for isolating the vacuum pump from the freeze dry system.
- Built-in stainless steel mini vacuum drying chamber, 5.1" w x 13.0" d x 2.5" h (12.9 cm x 33.0 cm x 6.4 cm), that includes 50-watt heater with microprocessor control to +60° C (+140° F), 3/4" thick clear acrylic lid and neoprene gasket. (Chamber is not cooled. The only cooling is from the frozen sample.)
- Domestic or international electrical configuration. Models wired for 115 volts, 60 Hz include a 3-wire cord with 20 amp NEMA 5-20P plug. Models wired for 220/240 volts, 50 Hz or 208/230 volts, 60 Hz include a 3-wire cord with 20 amp NEMA 6-20P plug.

All models require (not included):

- Vacuum pump with a displacement of at least 144 liters per minute, 0.002 mBar ultimate pressure. 15 amp NEMA 5-15P plug (115 volt models) or reverse IEC plug (220/240 or 208/230 volt models), and fitting suitable for 3/4" ID vacuum hose. See pages 44-46.
- Drying accessory. See pages 34-42.
- Freeze dry glassware if not bulk freeze drying. See pages 48-51.

See ordering information on page 29.

❖ Exclusive feature



FreeZone® Plus™ 12 Liter Cascade Freeze Dry Systems

SPECIFICATIONS

All models feature:

- Upright stainless steel collector coil and chamber with stainless steel baffle capable of removing 4 liters of water in 24 hours and holding 12 liters of ice before defrosting.
- Two 3/4 hp CFC-free and HCFC-free refrigeration systems, used in series, to cool collector to **-84° C (-119° F)**.
- Clear acrylic chamber lid, 3/4" thick, with neoprene gasket.
- ❖ Brushed stainless steel and glacier white, epoxy-coated steel exterior with blue accents.
- ❖ LCD that displays system operating parameters, set-up parameters and alarm messages. It may be user-configured to display vacuum in mBar, Pa or Torr and temperature in ° F or ° C. It also displays total number of hours of refrigeration system operation and time since the refrigeration was serviced and the total number of hours of vacuum pump operation and time since the vacuum pump was serviced (in hours).
- Red alarm light that flashes and beeper that sounds to indicate that an abnormal system event has occurred, including: power failure, improper line voltage supply, collector temperature rise above -40° C, service vacuum pump (after 1000 hours of vacuum use), and moisture in collector. Pressing the Menu Switch displays the alarm message on the LCD.
- LED vacuum and temperature "waves" for at-a-glance display of relative system vacuum and collector temperature.
- ❖ Moisture sensor that prevents refrigeration or vacuum start-up when moisture is detected in the collector chamber area.
- Vacuum control valve that maintains setpoint vacuum level.
- ❖ Vacuum break valve that bleeds air into the system when power to the freeze dryer or vacuum pump is shut off. If a power outage less than approximately 5 minutes occurs, the freeze dryer will restart and the refrigeration and vacuum system will resume operation once power is restored. If the power failure is more than approximately 5 minutes and the collector warms above safe limits, the freeze dryer will not automatically restart.
- Rear-mounted RS-232 port to transmit data to a user-supplied computer. Transmission intervals may be user-configured for 10, 30, 60, 300 or 600 seconds.
- Automatic start-up switch for collector cool-down and vacuum pull-down with manual override switches.
- Hot gas defrost and switch.
- Front-mounted, retractable, 9" collector drain hose.
- 3" diameter stainless steel port for connection of drying accessories (sold separately).
- Side-mounted power switch and rear-mounted electrical receptacle (for vacuum pump connection).
- 3" diameter casters.
- 3-wire cord with 20 amp NEMA 6-20P plug.
- 3/4" OD vacuum connection, three feet of 3/4" ID vacuum hose and two clamps.
- Overall dimensions: 32.2" w x 28.0" d x 36.3" h (84.8 cm x 71.1 cm x 92.1 cm).
- Usable interior space: 11.5" w x 24.5" d x 16.5" h (29.2 cm x 62.2 cm x 41.9 cm)

Models conform to the following standards:

- UL Standard 61010A-1 (60 Hz models).
- CAN/CSA C22.2 No. 1010.1 (60 Hz models).
- CE Conformity marking (220/240 volts, 50 Hz models).



FreeZone Plus 12 Liter Cascade Freeze Dry System with built-in vacuum drying chamber 7960046, 12-Port Drying Chamber 7522800 and miscellaneous glassware.

Options include:

- Teflon-coated collector coil and chamber for processes involving corrosive compounds.
- Purge valve with switch for isolating the vacuum pump from the freeze dry system.
- Built-in stainless steel mini vacuum drying chamber, 5.1" w x 13.0" d x 2.5" h (12.9 cm x 33.0 cm x 6.4 cm), that includes 50-watt heater with microprocessor control to +60° C (+140° F), 3/4" thick clear acrylic lid and neoprene gasket. (Chamber is not cooled. The only cooling is from the frozen sample.)
- Domestic or international electrical configuration.

All models require (not included):

- Vacuum pump with a displacement of at least 144 liters per minute, 0.002 mBar ultimate pressure, reverse IEC plug and fitting suitable for 3/4" ID vacuum hose. See pages 44-46.
- Drying accessory. See pages 34-42.
- Freeze dry glassware if not bulk freeze drying. See pages 48-51.

See ordering information on page 29.

❖ Exclusive feature



FreeZone® Plus™ 6 & 12 Liter Cascade Freeze Dry Systems

ORDERING INFORMATION

FreeZone® Plus™ 6 Liter Cascade Freeze Dry Systems

O P T I O N S I N C L U D E D					
Catalog Number	Electrical Requirements (without vacuum pump)	Teflon-Coated Collector Coil & Chamber	Purge Valve	Vacuum Drying Chamber	Shipping Weight
7934020	115 volts, 60 Hz, 11.0 A				270 lbs. (122 kg)
7934021	115 volts, 60 Hz, 11.0 A	•			270 lbs. (122 kg)
7934022	115 volts, 60 Hz, 11.0 A		•		273 lbs. (124 kg)
7934024	115 volts, 60 Hz, 11.0 A	•	•		273 lbs. (124 kg)
7934026	115 volts, 60 Hz, 11.0 A		•	•	288 lbs. (131 kg)
7934027	115 volts, 60 Hz, 11.0 A	•	•	•	288 lbs. (131 kg)
7934040	208/230 volts, 60 Hz, 5.5 A				270 lbs. (122 kg)
7934041	208/230 volts, 60 Hz, 5.5 A	•			270 lbs. (122 kg)
7934042	208/230 volts, 60 Hz, 5.5 A		•		273 lbs. (124 kg)
7934044	208/230 volts, 60 Hz, 5.5 A	•	•		273 lbs. (124 kg)
7934046	208/230 volts, 60 Hz, 5.5 A		•	•	288 lbs. (131 kg)
7934047	208/230 volts, 60 Hz, 5.5 A	•	•	•	288 lbs. (131 kg)
7934030*	220/240 volts, 50 Hz, 5.5 A				270 lbs. (122 kg)
7934031*	220/240 volts, 50 Hz, 5.5 A	•			270 lbs. (122 kg)
7934032*	220/240 volts, 50 Hz, 5.5 A		•		273 lbs. (124 kg)
7934034*	220/240 volts, 50 Hz, 5.5 A	•	•		273 lbs. (124 kg)
7934036*	220/240 volts, 50 Hz, 5.5 A		•	•	288 lbs. (131 kg)
7934037*	220/240 volts, 50 Hz, 5.5 A	•	•	•	288 lbs. (131 kg)

FreeZone® Plus™ 12 Liter Cascade Freeze Dry Systems

O P T I O N S I N C L U D E D					
Catalog Number	Electrical Requirements (without vacuum pump)	Teflon-Coated Collector Coil & Chamber	Purge Valve	Vacuum Drying Chamber	Shipping Weight
7960040	208/230 volts, 60 Hz, 6.5 A				319 lbs. (145 kg)
7960041	208/230 volts, 60 Hz, 6.5 A	•			319 lbs. (145 kg)
7960042	208/230 volts, 60 Hz, 6.5 A		•		322 lbs. (146 kg)
7960044	208/230 volts, 60 Hz, 6.5 A	•	•		322 lbs. (146 kg)
7960046	208/230 volts, 60 Hz, 6.5 A		•	•	337 lbs. (153 kg)
7960047	208/230 volts, 60 Hz, 6.5 A	•	•	•	337 lbs. (153 kg)
7960030*	220/240 volts, 50 Hz, 5.5 A				319 lbs. (145 kg)
7960031*	220/240 volts, 50 Hz, 5.5 A	•			319 lbs. (145 kg)
7960032*	220/240 volts, 50 Hz, 5.5 A		•		322 lbs. (146 kg)
7960034*	220/240 volts, 50 Hz, 5.5 A	•	•		322 lbs. (146 kg)
7960036*	220/240 volts, 50 Hz, 5.5 A		•	•	337 lbs. (153 kg)
7960037*	220/240 volts, 50 Hz, 5.5 A	•	•	•	337 lbs. (153 kg)

*International electrical configuration

Dry Ice Benchtop Freeze Dry System

For the laboratory with occasional lyophilization requirements, the Dry Ice Benchtop Freeze Dry System provides a simple, economical means of freeze drying. Since dry ice cools alcohol or other heat transfer solutions to approximately -75° C (-103° F), the Dry Ice Benchtop Freeze Dry System is ideal for processing materials with low eutectic points.

The Dry Ice Benchtop Freeze Dry System is equipped with a center well for dry ice and solvent that serves as a water vapor collector and doubles as a convenient pre-freezing bath. Flasks, serum bottles and ampules may be frozen by dipping and rotating them in the well.

7522700 Dry Ice Benchtop Freeze Dry System. Chamber, 9.8" h x 8.8" diameter (24.8 cm x 22.2 cm), type 304 stainless steel with twelve

valves and single run capacity of 1 liter. Valves accommodate either 1/2" or 3/4" flask adapters. Includes dry ice/solvent center well with 1.92 liter capacity and cover, 1/2" OD port for connection to vacuum pump and



3/8" OD port for connection to vacuum gauge. **Dry ice, vacuum pump, vacuum gauge, tubing and glassware are required (not included).** See pages 44-46 for vacuum pumps and accessories. See pages 48-51 for glassware. Shipping weight 11 lbs. (5 kg)



FreeZone® Triad™ Freeze Dry Systems

FEATURES & BENEFITS

FREEZONE TRIAD is an all-in-one benchtop cascade lyophilizer and stoppering tray dryer. Just add a vacuum pump and glassware and begin pre-freezing, freeze drying and stoppering under vacuum.

One large processing shelf may be used to pre-freeze samples in containers or bulk to -75°C . Dual refrigeration

systems cool to -85°C to freeze dry low eutectic point samples on the shelf or on four sample valves mounted to the left-hand side. After freeze drying, vials or serum bottles on the processing shelf may be stoppering under vacuum using a pneumatic mechanism that does not require compressed gas.

Four sample valves increase the capacity and flexibility of the freeze dryer. Four valves allow connection of flasks and other freeze dry glassware. Samples in the flasks and in the tray dryer may be lyophilized simultaneously.

❖ **Hot gas defrost.** Hot gas from the compressor is circulated through the collector coil and automatically shuts off when the refrigerant reaches $+60^{\circ}\text{C}$ ($+140^{\circ}\text{F}$) or after 3 hours.

Large clear acrylic door provides complete visibility of the processing shelf.

Automatic control of temperature enhances consistency and convenience of repetitive protocols. A microprocessor-based controller permits up to five different temperature programs to be stored and repeated, each using a timed pre-freezing segment plus as many as five different ramping and holding segments.



Rear-mounted RS-232 port may be used to transmit data to a user-supplied computer.

Rear-mounted electrical receptacle allows connection of the vacuum pump (pump sold separately).

❖ **Vacuum control/break valve maintains set point vacuum level to speed the freeze dry process.** At the same time, it protects the system from oil backstreaming by bleeding air into the system when power to the freeze dryer or vacuum pump is shut off. If a brief power outage occurs, the freeze dryer will restart and the refrigeration and vacuum system will resume operation once power is restored. If the power failure is longer and the collector warms above safe limits, the freeze dryer will not automatically restart, which prevents melted sample from being drawn into the vacuum pump.

❖ **Durable exterior of brushed stainless steel and glacier white epoxy-coated steel with blue accents.**



ETL listed. The 230 volt, 60 Hz model carries the ETL mark signifying it is certified to UL Standard 61010A-1 and CAN/CSA C22.2 No. 1010.1.



CE marking. The 230 volt, 50 Hz model conforms to the CE (European Community) requirements for electrical safety and electromagnetic compatibility.

1/8" OD backfill port introduces sterile air or inert gas from an outside source to the chamber, protecting samples from atmospheric moisture and contaminants.

❖ *Exclusive feature*



FreeZone® Triad™ Freeze Dry Systems

FEATURES & BENEFITS



❖ **Collector drain pan and hose.** A stainless steel drain pan (*above*) catches defrosted condensate, which may be conveniently emptied through the attached drain hose (*above, right*). The pan is removable for cleaning.

CFC/HCFC-free refrigeration system ensures environmentally-safe cooling.

Two refrigeration modules, used in series, cool the collector coil to -85°C (-121°F), ideal for freeze drying samples with low eutectic points. The same refrigeration system and a 1000-watt heater efficiently cool and heat the shelf. Temperature of the fluid circulating through channels in the shelf may be set to a pre-freeze temperature of -75°C (-103°F) or between -55°C to $+50^{\circ}\text{C}$ (-67 to $+122^{\circ}\text{F}$) for freeze drying and is maintained within 1°C of set point.

One sensor probe monitors sample temperature, which is digitally displayed on the LCD.

Chamber pre-freezes samples to save money and time. Samples may be frozen on the shelf, eliminating the need for a separate freezer and product transfer.



❖ **Built-in pneumatic mechanism stoppers containers on processing shelf.** Containers are stoppered while the chamber is under vacuum and **without the use of compressed gas.**

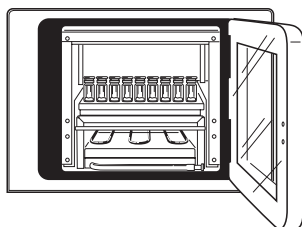

The shelf may be loaded with unstoppered vials or bottles. Stoppers should be inserted in container openings in the raised position.

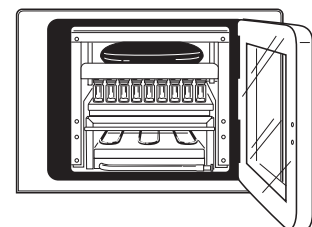

When the stoppering control is activated, atmospheric pressure causes the diaphragm to expand. Pressure from the expanding diaphragm forces the stoppering platen downward until it makes contact with the stoppers, forcing them into the containers.

Serum Bottle Capacity of the FreeZone Triad System

Size	Catalog Number	Shelf Capacity
2 ml	7575010	391
3 ml	7575210	441
5 ml	7573010	233
10 ml	7573210	196
20 ml	7573410	121
30 ml	7573610	86
50 ml	7573810	64
100 ml	7574010	42
125 ml	7574210	36

❖ *Exclusive feature*



FreeZone® Triad™ Freeze Dry Systems

FEATURES & BENEFITS

User-Friendly Control Panel

Green RUN/STOP indicator illuminates steadily while freeze drying is in progress and turns off when the RUN/STOP switch terminates a run. If a power failure occurs during processing, the indicator flashes when power is restored.

LCD prompts the user to set programming parameters and displays shelf, sample and collector temperatures in °C or °F; vacuum in mBar, Pa or Torr. When the automatic mode is selected, the display also indicates the program number selected, which segment of the program is in progress and the time remaining for that segment.

DISPLAY switch changes the screen format from SET UP to AUTO to MONITOR to MANUAL.

Green display indicators glow to signify which display format is shown.

Red LED Alarm indicator flashes and beeper sounds to indicate that an abnormal system event has occurred. Alarm messages are displayed on the LCD. The beeper mutes after one minute.

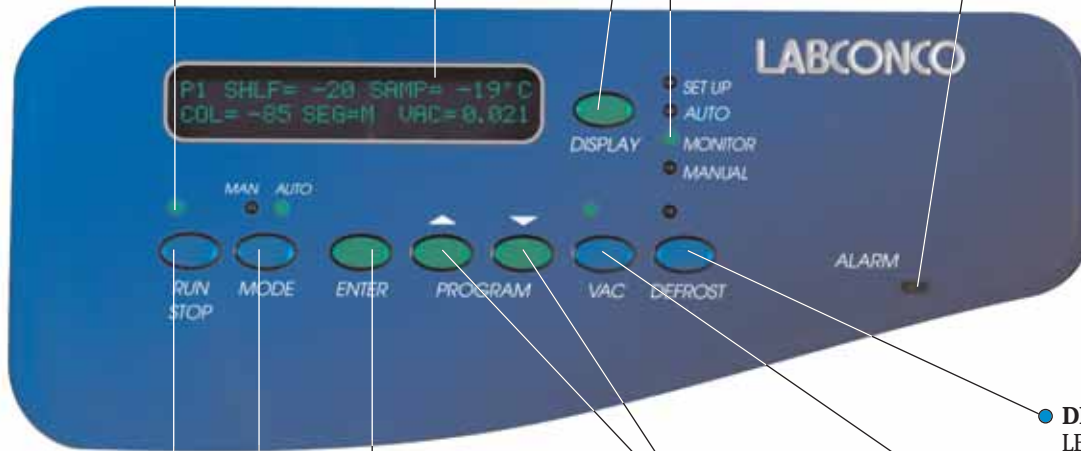

RUN/STOP switch initiates the start or stop of the lyophilization process.

MODE switch selects either manual or automatic operation.

ENTER switch is used in programming to enter a selected set point or program into memory.

“Up” and “down” arrows are used in programming to change a parameter set point or scroll through programs or choices.

DEFROST switch with LED indicator light controls the hot gas defrost function.

VACUUM switch with LED indicator light manually starts or stops the vacuum pump.

❄ Exclusive feature



FreeZone® Triad™ Freeze Dry Systems

SPECIFICATIONS & ORDERING INFORMATION

Specifications:

- ❖ Brushed stainless steel and glacier white, epoxy-coated steel exterior with blue accents.
- Large acrylic door, 1" thick, with neoprene gasket.
- Processing shelf, 12.4" w x 14.5" d (31.5 cm x 36.8 cm). Spacing between the shelf and top of the chamber accommodates containers with stoppers up to a maximum height of 148 mm and minimum height of 31 mm.
- ❖ Pneumatic stoppering mechanism that inflates the diaphragm and lowers the stoppering platen above the shelf. **No compressed gas is required.**
- One probe for monitoring sample temperature.
- Stainless steel collector coil capable of removing 1.84 liters of water in 24 hours and holding 2.5 liters of ice before defrosting.
- ❖ Two 1/3 hp CFC-free and HCFC-free refrigeration systems, used in series, to cool the collector to **-85° C (-121° F)** and work in concert with a 1000-watt heater to cool and heat fluid medium circulating through channels in the shelf. Fluid temperature may be set from -55° C to +50° C (-67° to +122° F) or to pre-freeze shelf temperature of -75° C (-103° F). Microprocessor controls circulating fluid temperature to ±1° C of set point.
- Four left-side mounted neoprene valve ports.
- LCD that displays shelf, sample and collector temperature in °C or °F, vacuum in mBar, Pa or Torr. When in Automatic mode, LCD also displays the program selected, the present segment that is ramping or holding, time remaining in present segment, and end of program.
- Microprocessor-controlled temperature programming from -55° C to +50° C (-67° to +122° F) during ramping and holding and -75° C (-103° F) during pre-freezing; and memory to store five programs, each with a pre-freeze segment plus five additional segments, for repetition of identical protocols.
- Control panel that includes Run/Stop, Mode, Enter, "Up" arrow, "Down" arrow, Vacuum, Defrost, and Display switches; green indicator lights for Run/Stop, Automatic and Manual mode, and Set Up, Automatic, Monitor and Manual display; red LED Alarm indicator; Stoppering control knob; Vacuum Release valve control knob; and 1/8" OD Back Fill port.
- ❖ Red LED Alarm indicator that flashes and beeper sounds to indicate that an abnormal system event has occurred, including: shelf temperature variation more than ±2° C as measured by the shelf temperature sensor, collector temperature above -40° C, vacuum pressure changes more than 0.500 mBar, shelf temperature outside of set point during ramping, power failure, unevenly loaded shelf during stoppering, and service vacuum pump (after 1000 hours of vacuum use). Alarm messages are displayed on the LCD. The beeper mutes after one minute.
- Vacuum control valve that maintains set point vacuum level.
- ❖ Vacuum break valve that bleeds air into the system when power to the freeze dryer or vacuum pump is shut off. If a brief power outage occurs, the freeze dryer will restart and the refrigeration and vacuum system will resume operation once power is restored. If the power failure is longer and the collector warms above safe limits, the freeze dryer will not automatically restart.



FreeZone Triad Freeze Dry System 7400040 and miscellaneous glassware.

- Rear-mounted RS-232 port to transmit data to a user-supplied computer. Transmission intervals may be user-configured for 10, 30, 60, 300 or 600 seconds.
- ❖ Hot gas defrost with switch and automatic shut off when refrigerant reaches +65° C (+149° F) or after 3 hours.
- ❖ Stainless steel condensate pan with drain hose.
- Left side-mounted power switch and rear-mounted electrical receptacle for vacuum pump connection.
- Overall dimensions: 28.5" w x 29.5" d x 28.0" h (72.4 cm x 74.9 cm x 71.1 cm).

Models conform to the following standards:

- UL Standard 61010A-1 (230 volt, 60 Hz model).
- CAN/CSA C22.2 No. 1010.1 (230 volt, 60 Hz model).
- CE Conformity marking (230 volt, 50 Hz model).

Option includes:

- Domestic or international electrical configuration.

All models require (not included):

- Vacuum pump with a displacement of at least 144 liters per minute, 0.002 mBar ultimate pressure, reverse IEC plug, and fitting suitable for 3/4" ID vacuum hose. See pages 44-46.
- Freeze dry glassware if not bulk freeze drying. See pages 48-51.

See page 39 for FreeZone Triad accessories.

Catalog Number	Electrical Requirements (without vacuum pump)	Shipping Weight
7400040	230V, 60 Hz, 12.0 A	450 lbs. (204 kg)
7400030*	230V, 50 Hz, 12.0 A	450 lbs. (204 kg)

* International electrical configuration

❖ Exclusive feature



FreeZone® Stoppering Tray Dryers

FEATURES & BENEFITS

Power switch turns all power to the Tray Dryer on or off.

Stoppering control regulates the up and down movement of the shelves while the chamber is under vacuum. See description on page 35.

Three sensor probes monitor sample temperature, which is digitally displayed on the LCD.

Clear acrylic viewing door provides complete visibility of the three process shelves.

Three large shelves, each with 196 square inches of space, accommodate bulk trays or batches of serum bottles, vials or ampules. Samples may be lyophilized and then stoppered, if desired, on three large adjustable shelves, each with 196 square inches of space. See the chart on page 35 for serum bottle capacities.

Chamber pre-freezes samples to save money and time. Samples may be frozen on the shelves, eliminating the need for a separate freezer and product transfer.

Separate 1 hp CFC-free refrigeration system and 1000-watt heater ensure efficient cooling and heating of the shelves. Temperature of fluid circulating through channels in the shelves may be set between -40° C and +40° C (-40° F and +104° F). A microprocessor maintains system temperature within 1° C of set point. The system uses a non-flammable refrigerant that contains no ozone-damaging chlorofluorocarbons (CFCs).

Automatic control of temperature enhances consistency and convenience of repetitive protocols. A microprocessor-based controller permits up to five different temperature programs to be stored and repeated, each using as many as five different segments. For each segment, the length of time the temperature should hold and rate at which the temperature should be increased or decreased may be programmed.

1/8" OD backfill port introduces sterile air or inert gas from an outside source to the chamber, protecting samples from atmospheric moisture and contaminants.

Optional Isolation Valve 7761500 isolates the Stoppering Tray Dryer from the Freeze Dry System to shorten time necessary to reestablish working vacuum levels and to provide a means for checking end point. While the researcher loads and pre-freezes samples on the shelves, the Isolation Valve may be closed allowing the Freeze Dry System's vacuum and collector to reach working levels. At the end of lyophilization, the valve may be closed to test the rate of vacuum decay in the Tray Dryer. Rapid decay indicates end point has not been reached. See page 35 for ordering information.

RS-232 cable connection port, located on the back, allows communication of the Stoppering Tray Dryer with the microprocessor of the Freeze Dry System when connected via the interconnect Cable 7353403 included. This communication permits 1) automatic start up of the vacuum pump to occur after time has elapsed in Segment 1 when the Stoppering Tray Dryer is used in the AUTO mode; 2) use of one computer to accept data from both the Stoppering Tray Dryer and the Freeze Dry System.



CE marking. The 208/230 volt, 50 Hz model conforms to the CE (European Community) requirements for electrical safety and electromagnetic compatibility.

Support stand simplifies connection to FreeZone 6, 12 or 18 Liter Freeze Dry System. Support stand completes the connection between the Tray Dryer attachment port and the Freeze Dry System of your choice. The stand elevates the Tray Dryer above the work surface of the Freeze Dry System to allow unobstructed access to the collector compartment or optional built-in vacuum drying chamber or shell freezer.

Vacuum release valve control vents the chamber so the chamber door may be opened. This control may also be used to introduce inert gas into the chamber when the gas line is connected to the backfill port.



ETL listed. Models for operation on 115 volts, 60 Hz or 220/240 volts, 60 Hz carry the ETL mark signifying they are certified to UL Standard 61010A-1 and CAN/CSA C22.2 No. 1010.1.



FreeZone® Stoppering Tray Dryers

FEATURES & BENEFITS

User-Friendly Control Panel

Green RUN/STOP indicator illuminates steadily while freeze drying is in progress and turns off when the programmed cycle is completed or if the process is terminated in mid-cycle.

LCD prompts the user to set programming parameters and displays system and probe temperatures in °C or °F and vacuum in mBar, Pa or Torr. When the automatic mode is selected, the display also indicates which segment of the program is in progress.

Red LED Alarm indicator flashes and beeper sounds to indicate that an abnormal system event has occurred, including: system temperature variation more than $\pm 2^{\circ}\text{C}$ as measured by the system temperature sensor, vacuum pressure changes more than 0.500 mBar, system temperature outside of set point during ramping, power failure, improper line voltage supply, and faulty temperature probe. Alarm messages are displayed on the LCD. The beeper mutes after one minute.

DISPLAY changes the screen format from SET UP to AUTO to MONITOR to MANUAL.

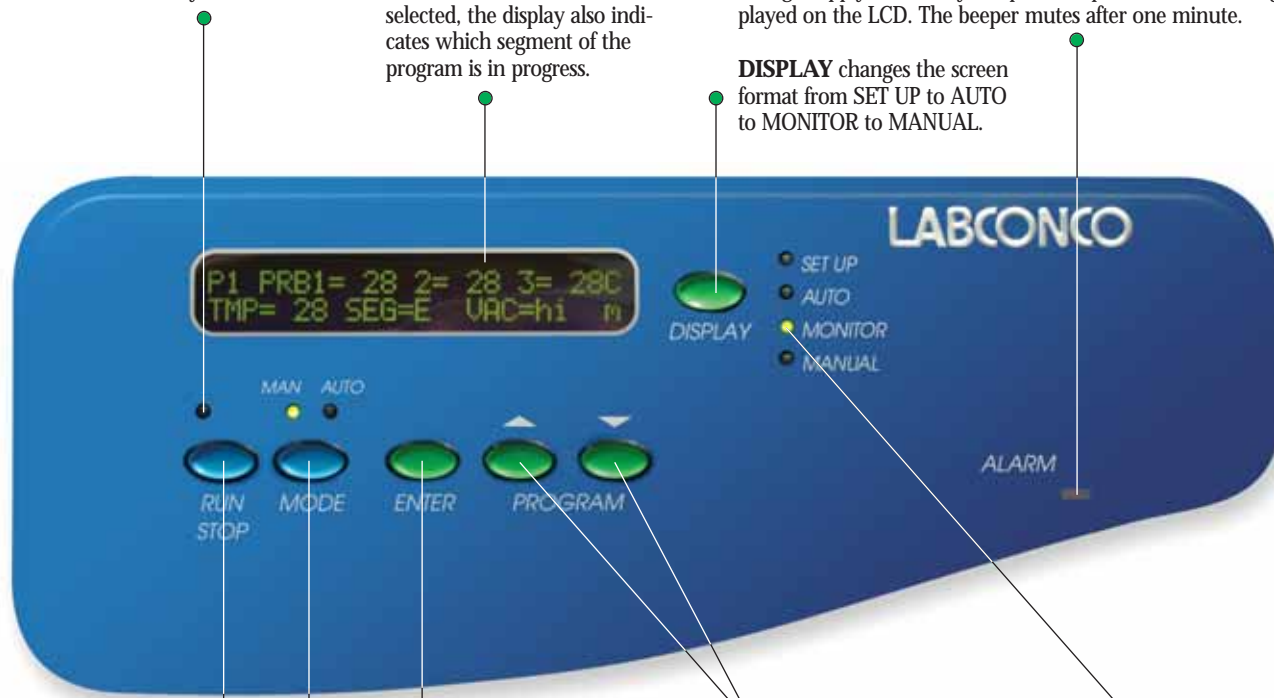

RUN/STOP switch initiates the start or stop of the lyophilization process.

MODE switch selects either manual or automatic operation.

ENTER is used in programming to enter a selected set point or program into memory.

“Up” arrow is used in programming to increase a parameter set point or scroll through programs or choices.

“Down” arrow is used in programming to decrease a parameter set point or scroll through programs or choices.

Green display indicators glow to signify which display format is shown. If a power failure occurs during processing, the indicator flashes when power is restored.

Built-in pneumatic mechanism stoppers containers on all three shelves.

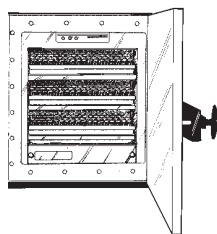

The Stoppering Tray Dryer may be loaded with unstoppered vials or bottles on all three shelves. Stoppers should be inserted in vial or bottle openings in the raised position.

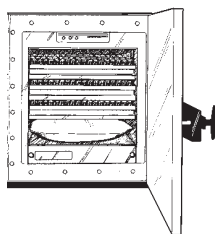

When the stoppering control is activated, atmospheric pressure causes the diaphragm to expand. Pressure from the expanding diaphragm causes the bottom shelf to rise until the loaded tray makes contact with the shelf above it.

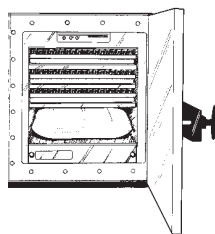

The diaphragm continues to expand until all three shelves have made contact with each other allowing all vials or bottles to be stoppered under vacuum.

Serum Bottle & Vial Capacity of the Stoppering Tray Dryer

Size	Catalog Number	Shelf Capacity	No. of Shelves	Total Capacity
2 ml	7575010	399	3	1197
3 ml	7575210	296	3	888
5 ml	7573010	255	3	765
5 ml	7762300	255	3	765
10 ml	7573210	195	3	585
10 ml	7762600	255	3	765
20 ml	7573410	132	3	396
30 ml	7573610	86	3	258
50 ml	7573810	72	2	144
100 ml	7574010	42	2	84
125 ml	7574210	36	1	36



FreeZone® Stoppering Tray Dryers

SPECIFICATIONS & ORDERING INFORMATION

Specifications:

- ❖ Brushed stainless steel and glacier white, epoxy-coated steel exterior with blue accents.
 - Acrylic door, 3/4" thick.
 - Three processing shelves, each 16.5" w x 12" d (41.9 cm x 30.5 cm) with 196 square inches of area. Spacing between the shelves accommodates containers with stoppers up to a maximum height of 75 mm and minimum height of 38 mm when three shelves are used, a maximum height of 107 mm and minimum height of 56 mm when two shelves are used, and a maximum height of 196 mm and minimum height of 114 mm when one shelf is used.
 - Three probes for monitoring sample or shelf temperature.
 - 3" diameter outlet, located on the bottom of the tray dryer cabinet, for connection to a FreeZone 6, 12 or 18 Liter Freeze Dry System (freeze dryer is required and not included).
 - 1 hp CFC-free refrigeration system and 1000-watt electric heater for cooling and heating fluid medium circulating through channels in the shelves from -40° C to +40° C (-40° to +104° F). Microprocessor controls circulating fluid temperature to ±1° C of set point.
- ❖ LCD that displays system and probe temperatures in ° C or ° F, vacuum in mBar, Pa or Torr, when in Monitor mode; and additionally, when in Auto mode, the segment of the program that is in progress, time remaining in present segment, and end of program.
- Microprocessor-controlled temperature ramp and hold programming from -40° C to +40° C (-40° to +104° F) and memory to store five programs and repetition of identical protocols.
- Control panel that includes Run/Stop, Mode, "Up" arrow, "Down" arrow, Enter and Display switches; green indicator lights for Run/Stop, Automatic and Manual mode, and Set Up, Automatic, Monitor and Manual display; red LED Alarm indicator; Stoppering control knob; Vacuum Release valve control knob; and 1/8" OD Back Fill port.
- ❖ Red LED Alarm indicator that flashes to indicate that an abnormal system event has occurred, including: system temperature variation more than ±2° C as measured by the system temperature sensor, vacuum pressure changes more than 0.500 mBar, system temperature outside of set point during ramping, power failure, improper line voltage supply, and faulty temperature probe. Alarm messages are displayed on the LCD. The beeper mutes after one minute.
- Rear-mounted RS-232 cable connection port and interconnect cable for communication of the Tray Dryer with the Freeze Dry System.
- Side-mounted power switch.
- Overall dimensions: 33.3" w x 24.6" d x 27.1" h (82.0 cm x 62.4 cm x 68.8 cm).

Models conform to the following standards:

- UL Standard 61010A-1 (60 Hz models).
- CAN/CSA C22.2 No. 1010.1 (60 Hz models).
- CE Conformity marking (220/240 volts, 50 Hz models).

Option includes:

- Domestic or international electrical configuration. Models wired for 115 volts, 60 Hz include a 3-wire cord with 20 amp NEMA 5-20P plug. Models wired for 230 volts, 50 or 60 Hz include a 3-wire cord with 15 amp NEMA 6-20P plug.



FreeZone Stoppering Tray Dryer 7948020, 6-Port Tray Dryer Manifold 7726500 and FreeZone 12 Liter Freeze Dry System 7754040.

All models require (not included):

- FreeZone 6, 12 or 18 Liter Freeze Dry System. The FreeZone Stoppering Tray Dryer and Freeze Dry System may be ordered as separate components or together as one catalog number on selected models of FreeZone 6 Liter Benchtop Freeze Dry Systems or FreeZone 6 or 12 Liter Freeze Dry Systems. See pages 18-29.
- Vacuum pump with a displacement of at least 144 liters per minute, 0.002 mBar ultimate pressure, 15 amp NEMA 5-15P plug (115 volt models) or reverse IEC plug (220/240 or 208/230 volt models), and fitting suitable for 3/4" ID vacuum hose. See pages 44-46.
- Freeze dry glassware if not bulk freeze drying. See pages 50-51.

Catalog Number	Electrical Requirements (without vacuum pump)	Shipping Weight
7948020	115V, 60 Hz, 16.0 A	422 lbs. (191 kg)
7948040	220/240V, 60 Hz, 9.0 A	422 lbs. (191 kg)
7948030*	208/230V, 50 Hz, 9.0 A	422 lbs. (191 kg)

See page 39 for Stoppering Tray Dryer accessories.

❖ Exclusive feature

* International electrical configuration



FreeZone® Bulk Tray Dryers

FEATURES & BENEFITS

Power switch turns all power to the Tray Dryer on or off.

RS-232 cable connection port, located on the back, allows communication of the Bulk Tray Dryer with an IBM-compatible, user-supplied computer. Parameters that may be monitored include shelf set point temperature, actual temperature of each shelf, run time and operating status. **RS-232 Cable is required (not included)**. See page 48.

Support stand simplifies connection to FreeZone 6, 12 or 18 Liter Freeze Dry System. Support stand completes the connection between the Tray Dryer attachment port and the Freeze Dry System of your choice. The stand elevates the Tray Dryer above the work surface of the Freeze Dry System to allow unobstructed access to the collector compartment or optional built-in vacuum drying chamber or shell freezer.



ETL listed. All 115 volt models carry the ETL mark signifying they are certified to UL Standard 61010A-1 and CAN/CSA C22.2 No. 1010.1.

Vacuum release valve control vents the chamber so the chamber door may be opened.

Clear acrylic viewing door provides visibility of the chamber interior.

Three shelves, each with a 200-watt heater, provide ample room for bulk samples or samples in serum bottles or vials. Each shelf is 12.7" w x 16.6" d (32.2 cm x 42.2 cm) to provide 210 square inches of area. Each shelf may be set above sample temperature up to +60° C (+140° F). A microprocessor maintains system temperature within 3° C of set point. (Shelves are not cooled. The only cooling is from the frozen sample.) The chamber can accommodate two additional shelves. See page 35 for ordering information.

Three sensor probes monitor sample temperature, which is digitally displayed on the LCD. Connections are provided for two additional sensor probes (Additional sensors are sold separately and as a component to Heated Shelves with Sensors).



Six-Port Manifold (models 7806021 and 7806031) increases flexibility and capacity of the FreeZone System. Six valves, which accommodate either 1/2" or 3/4" flask adapters, allow connection of flasks and other freeze dry glassware so that samples attached to the manifold and in the Tray Dryer may be lyophilized simultaneously.



CE marking. All 230 volt models conform to the CE (European Community) requirements for electrical safety and electromagnetic compatibility.

LCD displays set point temperature, actual temperatures and Run ("R") or Stop ("S") mode.



RUN/STOP switch initiates the Bulk Tray Dryer to control the temperature of the shelves at the set point temperature.

"Up" and "down" arrows are used in programming to change the set point temperature above sample temperature to +60° C (+140° F). The chamber is not cooled. The only cooling is from the frozen sample.

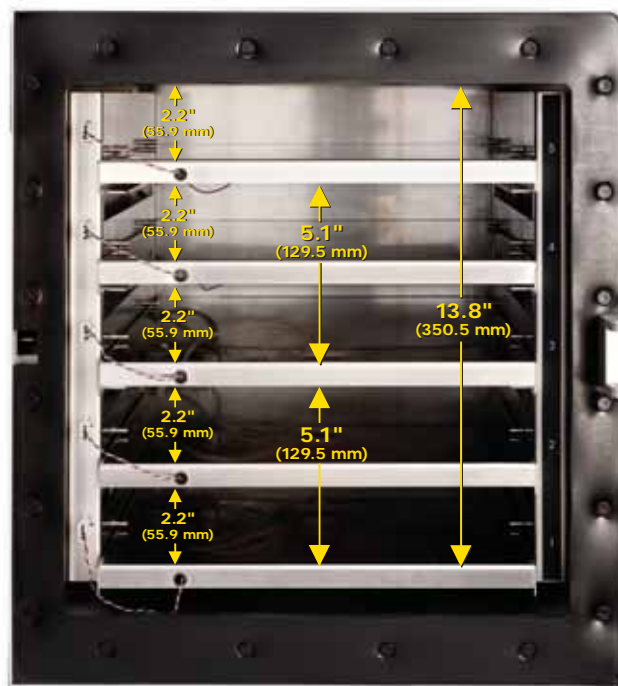



FreeZone® Bulk Tray Dryers

SPECIFICATIONS & ORDERING INFORMATION

Specifications:

- ❖ Brushed stainless steel and glacier white, epoxy-coated steel exterior with blue accents.
 - Acrylic door, 3/4" thick.
 - Three shelves, each 12.7" w x 16.6" d (32.2 cm x 42.2 cm) to provide 210 square inches of area. Chamber may accommodate two additional shelves (sold separately).
- ❖ 200-watt heater on each shelf for heating to +60° C (+140° F). A microprocessor maintains system temperature within 3° C of set point. (Shelves are not cooled by the Bulk Tray Dryer. The only cooling is from the frozen sample.)
- Three sensor probes for monitoring sample or shelf temperature. Connections for two additional sensors are provided (additional sensors sold separately).
- LCD that displays set point and temperature (°C) of each shelf and "R" for Run mode or "S" for Stop mode.
- Control panel with Run/Stop, "Up" arrow and "Down" arrow switches.
- Vacuum release valve for venting the chamber so the chamber door may be opened.
- Rear-mounted RS-232 cable connection port for communication with a user-supplied IBM-compatible computer. Monitored parameters are shelf set point temperature, actual temperature of each shelf, run time and operating status. **RS-232 Cable is required (not included).** See page 52.
- Side-mounted power switch.
- ❖ Integral Support Stand completes the connection between the Tray Dryer attachment port and the FreeZone 6, 12 or 18 Liter Freeze Dry System of your choice. The stand elevates the Tray Dryer above the work surface of the Freeze Dry System to allow unobstructed access to the collector compartment.
- Overall dimensions: 27.1" h x 32.2" w x 21.5" d (69 cm x 82 cm x 55 cm).

Models conform to the following standards:

- UL Standard 61010A-1 (115 volt models).
- CAN/CSA C22.2 No. 1010.1 (115 volt models).
- CE Conformity marking (230 volt models).

Options include:

- Pre-installed 6-Port Tray Dryer Manifold 7726500.
- Domestic or international electrical configuration. Models wired for 115 volts, 50/60 Hz include a 3-wire cord with 15 amp NEMA 5-15P plug. Models wired for 230 volts, 50/60 Hz include a 3-wire cord with 15 amp NEMA 6-15P plug.



FreeZone Bulk Tray Dryer with 6-Port Manifold 7806021 and FreeZone 12 Liter Freeze Dry System with Teflon-Coated Collector 7754041.

All models require (not included):

- FreeZone 6, 12 or 18 Liter Freeze Dry System. See pages 18-29.
- Vacuum pump with a displacement of at least 144 liters per minute, 0.002 mBar ultimate pressure, and fitting suitable for 3/4" ID vacuum hose. See pages 44-46.
- Freeze dry glassware if not bulk freeze drying. See pages 50-51.

Catalog Number	Electrical Requirements (without vacuum pump)	6-Port Manifold	Shipping Weight
7806020	115V, 50/60 Hz, 8 amps		262 lbs. (119 kg)
7806021	115V, 50/60 Hz, 8 amps	•	277 lbs. (126 kg)
7806030*	230V, 50/60 Hz, 4 amps		262 lbs. (119 kg)
7806031*	230V, 50/60 Hz, 4 amps	•	277 lbs. (126 kg)

See page 39 for Bulk Tray Dryer accessories.

❖ Exclusive feature

* International electrical configuration



FreeZone® Triad™, Stoppering Tray Dryers & Bulk Tray Dryers

ACCESSORIES

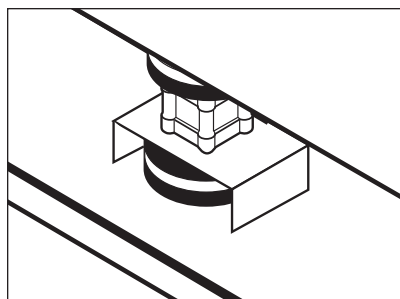

7761500 Isolation Valve

Isolates the Tray Dryer from the Freeze Dry System to shorten the time necessary to reestablish working vacuum levels and to provide a means for determining end point. Consists of a valve, valve handle, clamps, couplings and

installation instructions. Mounts underneath the support stand included with the Tray Dryer. May be installed before or after the Tray Dryer is installed on the Freeze Dry System. For use with Stoppering Tray Dryers 7948020, 7948030 and 7948040 and Bulk Tray Dryers 7806020 and 7806030. The Isolation Valve and 6-Port Tray Dryer Manifold 7726500 may not be field installed together.* Shipping weight 5 lbs. (2.3 kg)



7726500 6-Port Tray Dryer Manifold

30.0" w x 16.5" d x 7.0" h (76.2 cm x 41.9 cm x 17.8 cm). Six valves provide the flexibility to connect flasks and other freeze dry glassware to the Freeze Dry System with Tray Dryer. Valves accommodate either 1/2" or 3/4" flask adapters. Mounts to the support stand included with the FreeZone Stoppering and Bulk Tray Dryer. May be field installed before or after the Tray Dryer is installed on the Freeze Dry System. The 6-Port Tray Dryer Manifold and Isolation Valve 7761500 may not be field installed together.* Included with Bulk Tray Dryer 7806021 and 7806031. Shipping weight 19 lbs. (8.6 kg)



7516200 Support Grid

7.0" w x 7.0" d (17.8 cm x 17.8 cm), has stainless steel tray with removable plastic grid to provide support for Stoppering Ampules and other small specimen containers. Grid holds 144 containers of 12 mm diameter. Shipping weight 2.5 lbs. (1.1 kg)



7756200 Bulk Tray

11.5" w x 15.0" d x 0.8" h (29.2 cm x 38.1 cm x 2.0 cm). Stainless steel tray contains liquids for pre-freezing and bulk drying. Shipping weight 3 lbs. (1.4 kg)



7756100 Tray with Slide-Out Bottom

12.0" w x 14" d (30.5 cm x 35.6 cm). Stainless steel tray has separate bottom that slides out to allow glassware containers direct contact with shelf. Shipping weight 5 lbs. (2.3 kg)



7439300 Microcentrifuge Tube Holder.

3.0" w x 2.25" d x 1.0" h (7.6 cm x 5.7 cm x 2.5 cm), anodized aluminum block with twelve bore holes that accommodate 17 ml microcentrifuge tubes. Holder may be placed on any flat freeze drying surface such as inside Clear Chambers, Heated

Drying Chambers, or the built-in vacuum drying chamber of FreeZone Console Systems; or on FreeZone Stoppering or Bulk Tray Dryer Shelves, Product Shelves, or Heated Product Shelves. One each. **Microcentrifuge tubes are not included.** Shipping weight 0.6 lb. (0.3 kg)

For FreeZone Stoppering Tray Dryers

7756300 Shelf Spacers

9.0" w x 13.0" d x 2.5" h (22.9 cm x 33.0 cm x 6.4 cm). Stainless steel spacers placed on one or two empty shelves assist stoppering of partial loads of small vials or bottles. One pair. Shipping weight 3 lbs. (1.4 kg)

For FreeZone Bulk Tray Dryers

Heated Shelves with Sensors

12.7" w x 16.6" d (32.2 cm x 42.2 cm). Stainless steel shelves include 200-watt heater and sensor probe. FreeZone Bulk Tray Dryers include three and can accommodate two additional Heated Shelves with Sensors. The Sensor, included with the Heated



Shelf or sold separately, may be used to monitor sample or shelf temperature, which is displayed on the LCD of the FreeZone Bulk Tray Dryer.

Catalog Number	Description	Shipping Weight
7760800	Heated Shelf with Sensor for 115 volt, 50/60 Hz operation	15 lbs. (6.8 kg)
7760801	Heated Shelf with Sensor for 230 volt, 50/60 Hz operation	15 lbs. (6.8 kg)
7754100	Sensor only	0.5 lb. (0.2 kg)

* Contact Labconco for ordering information on models with factory-installed 6-Port Tray Dryer Manifold and Isolation Valve.



Drying Accessories

Use the key below to select the drying chamber or manifold that will fit the FreeZone System you have selected.

- 1** = Fits any FreeZone 1 Liter Freeze Dry System
- 2.5** = Fits any FreeZone 2.5 Liter Freeze Dry System
- 4.5** = Fits any FreeZone 4.5 Liter Freeze Dry System

- 4.5+** = Fits any FreeZone 4.5 Liter Freeze Dry System with Attachment Port Lid Accessory 7762800 attached (sold separately)
- 6** = Fits any FreeZone 6 Liter Freeze Dry System
- 12** = Fits any FreeZone 12 Liter Freeze Dry System
- 18** = Fits any FreeZone 18 Liter Freeze Dry System



7522800 12-Port Drying Chamber
9.75" h x 8.0" diameter (24.8 cm x 20.3 cm), type 304 stainless steel, 1/2" thick acrylic lid with neoprene gasket, complete

with 12 neoprene valves with molded plastic knobs that accommodate both 1/2" and 3/4" adapters for connection of flasks. Shipping weight 11 lbs. (5 kg) **1, 2.5, 6, 12, 18**



7522900 16-Port Drying Chamber
13.0" h x 13.0" diameter (33 cm x 33 cm), type 304 stainless steel, 3/4" thick acrylic lid with neoprene gasket, complete

with 16 neoprene valves with molded plastic knobs that accommodate both 1/2" and 3/4" adapters for connection of flasks. Shipping weight 21 lbs. (9.5 kg) **6, 12, 18**



Clear Chambers with Valves
Provide visibility into the acrylic chamber during bulk drying as well as accommodate connection of freeze dry glassware to

eight valves. Include clear acrylic cylinder; anodized aluminum lid; eight neoprene valves with molded plastic knobs for use with both 1/2" and 3/4" adapters; clear acrylic attachment port lid with 3" diameter opening and neoprene gasket.



Clear Chambers
Provide visibility into the chamber during bulk drying. Include clear acrylic lid with neoprene gasket, vacuum release valves and pass-through

for electrical transformer cords, clear acrylic attachment port lid with 3" diameter opening and neoprene gasket.

Catalog Number	Dimensions	Port Lid	Accommodate	For use with:	Shipping Wt.
7443500	Cylinder 9.25" dia. x 9.75" h (23.5 cm x 24.4 cm)	1/2"	Product Shelves 7442100 Heated Product Shelves 7418000 and 7418001	1, 2.5, 6, 12, 18	13.5 lbs. (5.9 kg)
	Overall 14.6" dia. x 12.2" h (37.1 cm x 31.0 cm)				
7444000	Cylinder 12.0" dia. x 12.6" h (30.5 cm x 38.0 cm)	3/4"	Product Shelves 7442100 Heated Product Shelves 7418000, 7418001, 7509400 and 7509401	6, 12, 18	15 lbs. (6.8 kg)
	Overall 17.3" dia. x 15.0" h (43.9 cm x 38.1 cm)				

Catalog Number	Dimensions	Port Lid	Accommodate	For use with:	Shipping Wt.
7442900	Cylinder 9.25" dia. x 9.75" h (23.5 cm x 24.4 cm)	1/2"	Product Shelves 7442100 Heated Product Shelves 7418000 and 7418001	1, 2.5, 4.5, 6, 12, 18	13.5 lbs. (5.9 kg)
	Overall 10.3" dia. x 13.1" h (26.2 cm x 33.3 cm)				
7867000	Cylinder 12.0" dia. x 12.6" h (30.5 cm x 36.6 cm)	3/4"	Product Shelves 7442100 and 7441700, Heated Product Shelves, 7418000, 7418001, 7509400 and 7509401	6, 12, 18	15 lbs. (6.8 kg)
	Overall 13.6" dia. x 16.3" h (34.5 cm x 41.4 cm)				



Drying Accessories



Clear Stopping Chambers

23.0" h x 13.5" diameter (58.4 cm x 34.3 cm). Provide an economical means of stoppering serum bottles under original vacuum. Consists of clear acrylic cylinder, stainless steel top plate, two 10.0" diameter aluminum shelves and low voltage transformer with variable heat control to +40° C (±104° F) and electrical cord with plug. Clear, 3/4" thick acrylic lid has neoprene gasket, vacuum release valve and stoppering handle. Also include 3/4"

thick, clear acrylic attachment port lid with 3" diameter opening; neoprene gasket and pass-through for electrical transformer cord. Serum bottles or vials with stoppers in the raised position may be loaded on the two shelves. After freeze drying is complete, the stoppering handle may be turned, slowly moving the top plate downward until it makes contact with the sample containers on the top shelf and the sample containers on the bottom shelf make contact with the top shelf. Pressure from the top plate and shelf push the stoppers into the containers, stoppering them under vacuum. Accommodate small containers from 2 to 5 milliliters.

Catalog Number	Electrical Requirements	For use with:	Shipping Weight
7868020	115 volts, 50/60 Hz	6, 12, 18	30 lbs. (13.6 kg)
7868030	230 volts, 50/60 Hz	6, 12, 18	30 lbs. (13.6 kg)



Heated Drying Chambers

10.5" h x 9.0" diameter (26.7 cm x 22.9 cm), type 304 stainless steel, with 1/2" thick, clear acrylic cover, neoprene gaskets and electrical pass-through for transformer cords. Include three shelf product heater consisting of three 6.5" diameter aluminum shelves with 1/4" rims, three stainless steel support rods, nine clips for shelf height adjustment, low voltage transformer with variable heat control to +40° C (+104° F), and three rubber feet.

Catalog Number	Electrical Requirements	For use with:	Shipping Weight
7521000	115 volts, 50/60 Hz	4.5+, 6, 12, 18	19.0 lbs. (8.6 kg)
7521001*	230 volts, 50/60 Hz	4.5+, 6, 12, 18	19.0 lbs. (8.6 kg)

Product Shelves Accommodate bulk samples, microtiter plates, vials or serum bottles.



Product Shelves

Consist of three aluminum shelves with 1/4" rims, three stainless steel support rods, nine clips for shelf height adjustment, and three rubber feet.



Heated Product Shelves with Variable Heat Control

Consist of three aluminum shelves with 1/4" rims, three stainless steel support rods, nine clips for shelf height adjustment, low voltage transformer with variable heat control to +40° C (+104° F), and three rubber feet.

Product Shelves

Catalog Number	Shelves Dimensions	For use with:	Shipping Weight
7442100	9.4" h. x 7.25" dia. (23.9 cm x 18.4 cm)	Chambers 7522900, 7442900, 7443500, 7444000 and 7867000	1.5 lbs. (0.7 kg)
7441700	12.2" h. x 9.9" dia. (31.0 cm x 25.1 cm)	Chambers 7522900, 7444000 and 7867000	2.0 lbs. (0.9 kg)

Heated Product Shelves with Variable Heat Control

Catalog Number	Shelves Dimensions	Electrical Requirements	For use with:	Shipping Weight
7509200	6.5" dia. x 9.0" h (16.5 cm x 22.9 cm)	115 volts, 60 Hz	Chambers 7522800, 7522900, 7443500, 7444000, 7442900 and 7867000	13 lbs. (5.9 kg)
7418000	7.25" dia. x 9.4" h (18.1 cm x 23.9 cm)	115 volts, 60 Hz	Chambers 7522900, 7443500, 7444000, 7442900 and 7867000	14 lbs. (6.4 kg)
7509400	10.0" dia. x 11.75" h (24.5 cm x 29.8 cm)	115 volts, 60 Hz	Chambers 7522900, 7444000 and 7867000	15 lbs. (6.8 kg)
7509201*	6.5" dia. x 9.0" h (16.5 cm x 22.9 cm)	230 volts, 50 Hz	Chambers 7522800, 7522900, 7443500, 7444000, 7442900 and 7867000	13 lbs. (5.9 kg)
7418001*	7.25" dia. x 9.4" h (18.1 cm x 23.9 cm)	230 volts, 50 Hz	Chambers 7522900, 7443500, 7444000, 7442900 and 7867000	14 lbs. (6.4 kg)
7509401*	10.0" dia. x 11.75" h (24.5 cm x 29.8 cm)	230 volts, 50 Hz	Chambers 7522900, 7444000 and 7867000	15 lbs. (6.8 kg)

* International electrical configuration



Drying Accessories



7522200 4-Port Manifold
9.0" h x 8.7" w x 8.7" d (22.9 cm x 22.1 cm x 22.1 cm), type 304 stainless steel, complete with four neoprene valves with molded plastic knobs that accommodate both 1/2" and 3/4" adapters for connection of flasks. Shipping weight 2 lbs. (1 kg)
1, 2.5, 4.5+



7522500 20-Port Manifold with Support Shelves
10.0" h x 29.6" w x 24.0" d (25.4 cm x 75.2 cm x 61.0 cm), type 304 stainless steel, complete with twenty neoprene valves with molded plastic knobs that accommodate

both 1/2" and 3/4" adapters and two adjustable aluminum support shelves with stainless steel rods. Shipping weight 15 lbs. (6.8 kg) **6, 12, 18**



7522300 20-Port Manifold
11.0" h x 19.0" w x 8.7" d (27.9 cm x 48.3 cm x 22.1 cm), type 304 stainless steel, complete with 20 neoprene valves with molded plastic knobs that accommodate both 1/2" and 3/4" adapters for connection of flasks. Shipping weight 15 lbs. (6.8 kg) **1, 2.5, 4.5+, 6, 12, 18**

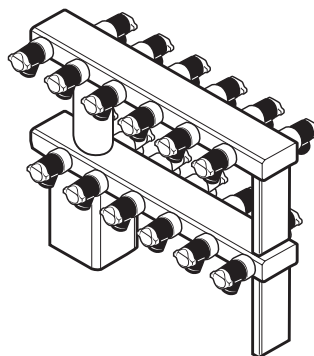

7548000 24-Port Two-Tier Manifold
20.0" h x 26.4" w x 10.6" d (50.8 cm x 67.1 cm x 26.9 cm), type 304 stainless steel, complete with 24 neoprene valves with molded plastic knobs that accommodate both 1/2" and 3/4" adapters for connection of flasks. Shipping weight 20 lbs. (9.1 kg)



7522400 10-Port Manifold with Support Shelf
10.0" h x 29.6" w x 14.5" d (25.4 cm x 75.2 cm x 36.8 cm), type 304 stainless steel, complete with ten neoprene valves with molded plastic knobs that accommodate both 1/2" and 3/4" adapters and adjustable aluminum support shelf with stainless steel rods. Shipping weight 11 lbs. (5 kg)
6, 12, 18



7868500 48-Port Ampule Manifold
28.6" h x 5.0" w x 5.0" d (72.7 cm x 12.7 cm x 12.7 cm), type 304 stainless steel, tree-type, with 48 each 1/4" OD pipe stems that accommodate gum rubber or similar tubing to fit over any Labconco Ampule. **Tubing is not included.** Shipping weight 12 lbs. (5.4 kg)
1, 2.5, 4.5+, 6, 12, 18



7762800 Attachment Port Lid
10.38" diameter (26.4 cm), replaces the lid to the drying chamber on FreeZone 4.5 Liter Systems, to permit use of the Heated Drying Chamber 7521000, 4-Port Manifold

7522200, 20-Port Manifold 7522300, 48-Port Manifold 7868500 or Clear Chamber 7867000. Includes 3/4" thick, clear acrylic cover with 3" diameter opening and gasket and acrylic plug with gasket (for periods of non-use). Shipping weight 2.0 lbs. (0.9 kg)



Secondary Traps

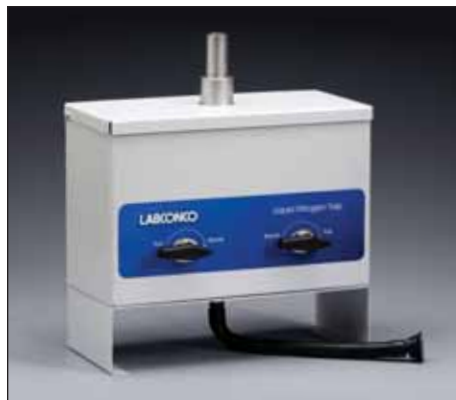

**7394800
Liquid Nitrogen
Secondary Trap**
For processing sam-
ples with ultra low
eutectic points.
Secondary Trap con-
nects in series with
a freeze dry system
and vacuum pump
to prevent contami-
nants from migrat-

ing into the vacuum pump. After pulling a vacuum, liquid nitrogen may be introduced via the liquid nitrogen port. Liquid nitrogen cools to -196°C (-321°F) to trap contaminants with low eutectic points. The well may be defrosted and the liquid drained from the drain hose. Glacier white epoxy-coated steel construction. Two valves may be opened (trap) or closed (by-pass). Opened valves allow gaseous contaminants to be trapped in the liquid nitrogen well. Closed valves allow gaseous contaminants to by-pass the well during defrosting and draining. 3/4" OD inlet and outlet connections. Includes an insulated filler tube for connection to a user-supplied liquid nitrogen tank; 20" rubber tubing, 3/4" ID x 3/8" wall; and two clamps. **Liquid nitrogen is required (not included).** Shipping weight 24 lbs. (10.9 kg)



7772000 Soda Acid Trap

Secondary trap connects in series with freeze dry system and vacuum pump to prevent migration of corrosive chemicals into pump interior. Clear acrylonitrile body allows visual check of color indicating media. Media changes from white to blue when exhausted. 3/4" OD inlet and outlet connections. Includes 20" rubber tubing, 3/4" ID x 3/8" wall, and one clamp. Shipping weight 12 lbs. (5.4 kg)

7772100 Replacement Cartridge for Soda Acid Trap 7772000

Shipping weight 4 lbs. (1.8 kg)

7772500 Activated Carbon Solvent Trap

Secondary trap connects in series with freeze dry system and vacuum pump to prevent migration of organic solvents into pump interior. Cartridge contains 14 ounces of activated carbon media. 3/4" OD inlet and outlet connections. Includes 20" rubber tubing, 3/4" ID x 3/8" wall, and one clamp. Shipping weight 12 lbs. (5.4 kg)

7772600 Replacement Cartridge for Activated Carbon Solvent Trap

Shipping weight 4 lbs. (1.8 kg)



Dry Ice Secondary Traps

For processing
samples with low
eutectic points.
Traps connect in
series with a freeze
dry system and
vacuum pump to
prevent contami-
nants from migrat-
ing into the vacuum
pump. An insulated

well, when dry ice and solvent are added, cools to approximately -75°C (-103°F). When used alone, Dry Ice Secondary Traps may serve as an inexpensive collector. Simply connect a sample directly to the incoming port and add a vacuum pump to the outgoing port. **Dry ice and solvent, such as alcohol, are required (not included).**

Catalog Number	Dimensions (h x diameter)	Inlet/Outlet Connections	Well Volume	Ice Trapping Capacity	Shipping Weight
7538000	9.75" x 7.8"	3/4" OD	3.10 liters	900 ml	9 lbs. (4.1 kg)
7538200	9.75" x 7.8"	1/2" OD	3.10 liters	900 ml	9 lbs. (4.1 kg)
7538400	7.8" x 6.6"	1/2" OD	1.92 liters	200 ml	5 lbs. (2.3 kg)



Rotary Vane Vacuum Pumps

Rotary Vane Vacuum Pumps provide the performance required for good freeze drying results and fit easily into the cabinets of FreeZone console models. Belt driven pumps of equivalent performance are also suitable; however, due to the large size of these pumps, they may not fit into the FreeZone System's cabinet.

Use the Selection Guide below to find the recommended General Purpose or Chemical-Resistant Vacuum Pump(s) based on your sample type and FreeZone System's electrical configuration.

Selection Guide

FreeZone Freeze Dry System	Sample Type	Recommended Vacuum Pump(s)		See Page
		With 115 volt plug	With 230 volt reverse IEC plug	
1 Liter Benchtop 7740020, 7740021	Aqueous Acids and/or Solvents	1472100, 7438700 7769600		45 46
7740030, 7740031, 7740040, 7740041	Aqueous Acids and/or Solvents		7739402, 7438900 7769800	45 46
2.5 Liter Benchtop 7670520, 7670521	Aqueous Acids and/or Solvents	1472100, 7438700 7769600		45 46
7670530, 7670531, 7670540, 7670541	Aqueous Acids and/or Solvents		7739402, 7438900 7769800	45 46
2.5 Liter Cascade Benchtop & Console 7670020, 7670021, 7420020, 7420021	Aqueous Acids and/or Solvents	1472100, 7438700 7769600		45 46
7670030, 7670031, 7670040, 7670041, 7420030, 7420031, 7420040, 7420041	Aqueous Acids and/or Solvents		7739402, 7438900 7769800	45 46
2.5 Liter Cascade Triad 7400040, 7400030	Aqueous Acids and/or Solvents		7739403, 7439200 7769800	45
4.5 Liter Benchtop & Console 7750020, 7750021, 7751020, 7751021	Aqueous Acids and/or Solvents	1472100, 7438700 7769600		45 46
7750030, 7750031, 7750040, 7750041, 7751030, 7751031, 7751040, 7751041	Aqueous Acids and/or Solvents		7739402, 7438900 7769800	45 46
6 Liter Benchtop & Console 7752020, 7752021, 7758020, 7758021, 7753026, 7753020, 7753021, 7753022, 7753024, 7753027, 7758520, 7758521, 7758522, 7758524	Aqueous Acids and/or Solvents	1467700, 7439000 7769600		45 46
7752030, 7752031, 7752040, 7752041, 7758030, 7758031, 7758040, 7758041, 7753030, 7753031, 7753032, 7753034, 7753042, 7753044, 7753046, 7753047, 7753532, 7753534, 7753542, 7753544, 7758530, 7758531, 7758532, 7758534, 7758540, 7758541, 7758542, 7758544	Aqueous Acids and/or Solvents		7739403, 7439200 7769800	45 46
6 Liter Cascade Console 7934020, 7934021, 7934022, 7934024, 7934026, 7934027	Aqueous Acids and/or Solvents	1467700, 7439000 7769600		45 46
7934030, 7934031, 7934032, 7934034, 7934036, 7934037, 7934040, 7934041, 7934042, 7934044, 7934046, 7934047	Aqueous Acids and/or Solvents		7739403, 7439200 7769800	45 46
12 Liter Console 7754040, 7754041, 7754042, 7754044, 7754046, 7754047, 7754030, 7754031, 7754032, 7754034, 7754036, 7754037, 7759040, 7759041, 7759042, 7759044, 7759030, 7759031, 7759032, 7759034	Aqueous Acids and/or Solvents		7739403, 7439200 7769800	45 46
12 Liter Cascade Console 7960030, 7960031, 7960032, 7960034, 7960036, 7960037, 7960040, 7960041, 7960042, 7960044, 7960046, 7960047	Aqueous Acids and/or Solvents		7739403, 7439200 7769800	45 46
18 Liter Console 7755030, 7755031, 7755032, 7755034, 7755036, 7755037, 7755040, 7755041, 7755042, 7755044, 7755046, 7755047	Aqueous Acids and/or Solvents		7739403, 7439200 7769800	45 46



Rotary Vane Vacuum Pumps



General Purpose Rotary Vane Vacuum Pumps

- Designed for use with aqueous samples.
- Compatible with FreeZone Freeze Dry Systems, CentriVap® Centrifugal Concentrators and Protector® Controlled Atmosphere Glove Boxes.
- Ultimate vacuum (total pressure) 2×10^{-3} mBar (1.5 micron).
- On/off switch.
- Two inlet adapters (1/2" and 3/4" OD).
- Mode selector with two positions: High Vacuum and High Throughput.
- Gas ballast with three positions: Closed, Low Flow and High Flow.
- Single phase direct drive motor, totally enclosed and fan cooled. Should the motor overheat, the thermal overload device switches off the pump. When the pump cools down, the motor automatically restarts.
- Isolation valve seals the inlet to prevent oil and air contamination of the system in the event of power failure.
- Cast aluminum casing and rubber feet.
- Include four each one liter bottles of vacuum pump oil and one exhaust filter with oil mist and odor filter elements.
- Retractable lifting handle (Models 1472100, 7739400 and 7739402).
- Lifting bracket (Models 1467700, 7739401 and 7739403).

Catalog Number	Electrical Configuration	Displacement At 60 Hz (50 Hz) liters/minute	Dimensions w x d x h inches (cm)	Shipping Weight lbs. (kg)
1472100	115 volts, 50/60 Hz, 4.6 A Includes 115 volt NEMA 5-15P plug.	117 (98)	6.5 x 17.0 x 10.4 (15.8 x 43.0 x 26.1)	62 (28)
7739400**	230 volts, 50/60 Hz, 2.4 A Includes 220 volt NEMA 6-15P plug.	117 (98)	6.5 x 17.0 x 10.4 (15.8 x 43.0 x 26.1)	62 (28)
7739402	230 volts, 50/60 Hz, 2.4 A Includes 230 volt reverse IEC plug.	117 (98)	6.5 x 17.0 x 10.4 (15.8 x 43.0 x 26.1)	62 (28)
1467700	115 volts, 50/60 Hz, 7.8 A Includes 115 volt NEMA 5-15P plug.	195 (163)	6.5 x 18.5 x 10.4 (15.8 x 47.0 x 26.1)	65 (30)
7739401**	230 volts, 50/60 Hz, 4.0 A Includes 220 volt NEMA 6-15P plug.	195 (163)	6.5 x 18.5 x 10.4 (15.8 x 47.0 x 26.1)	65 (30)
7739403	230 volts, 50/60 Hz, 4.0 A Includes 230 volt reverse IEC plug.	195 (163)	6.5 x 18.5 x 10.4 (15.8 x 47.0 x 26.1)	65 (30)

** Not for direct electrical connection to FreeZone Systems in this catalog.

General Purpose Rotary Vane Vacuum Pumps

- Designed for use with aqueous samples.
- Compatible with FreeZone Freeze Dry Systems, CentriVap Centrifugal Concentrators and Protector Controlled Atmosphere Glove Boxes.
- Ultimate vacuum (partial pressure) 1.3×10^{-4} mBar (0.1 micron).
- UNIBARB* 1/2" and 3/4" OD inlet adapter.
- Isolation valve seals the inlet to prevent oil and air contamination of the system in the event of power failure.
- Single phase, direct drive motor, totally enclosed, fan cooled with overload protection.
- Infinitely adjustable, leak-tight gas ballast control and positive shut-off.
- 1-20 threaded exhaust connection.
- Include one liter bottle of DirecTorr® Gold Oil and one oil mist exhaust filter that captures oil mist from the exhaust port and reduces pump noise to 50 dB.

*DirecTorr® is a registered trademark and UNIBARB® is a trademark of Thomas Industries, Inc.

Catalog Number	Electrical Configuration	Displacement At 60 Hz (50 Hz) liters/minute	Dimensions w x d x h inches (cm)	Shipping Weight lbs. (kg)
7438700	115 volts, 50/60 Hz, 5.8 A Includes 115 volt NEMA 5-15P plug.	108 (90)	6.5 x 18.5 x 9.6 (16.5 x 47.0 x 24.3)	47 (21)
7438800**	230 volts, 50/60 Hz, 2.9 A Includes 220 volt NEMA 6-15P plug.	108 (90)	6.5 x 18.5 x 9.6 (16.5 x 47.0 x 24.3)	47 (21)
7438900	230 volts, 50/60 Hz, 2.9 A Includes 230 volt reverse IEC plug.	108 (90)	6.5 x 18.5 x 9.6 (16.5 x 47.0 x 24.3)	47 (21)
7439000	115 volts, 50/60 Hz, 5.8 A Includes 115 volt NEMA 5-15P plug.	173 (144)	6.5 x 18.5 x 9.6 (16.5 x 47.0 x 24.3)	53 (24)
7439100**	230 volts, 50/60 Hz, 2.9 A Includes 220 volt NEMA 6-15P plug.	173 (144)	6.5 x 18.5 x 9.6 (16.5 x 47.0 x 24.3)	53 (24)
7439200	230 volts, 50/60 Hz, 2.9 A Includes 230 volt reverse IEC plug.	173 (144)	6.5 x 18.5 x 9.6 (16.5 x 47.0 x 24.3)	53 (24)

** Not for direct electrical connection to FreeZone Systems in this catalog.



Rotary Vane Vacuum Pumps & Vacuum Pump Accessories



Chemical-Resistant Rotary Vane Vacuum Pumps

- Designed for use with acids and other harsh chemicals including TFA, TFA by-products, acetonitrile, HBe and HNO₃ present in samples such as HPLC-prepared and peptide purified materials.
- Compatible with FreeZone Freeze Dry Systems and CentriVap Centrifugal Concentrators.
- Ultimate vacuum (partial pressure) 1.3×10^{-4} mBar (0.1 micron)
- UNIBARB 1/2" and 3/4" OD inlet adapter.
- Integral oil filtration/acid neutralization system.
- Larger oil reservoir (approximately 1.3 liters) protects the pump by diluting contaminants.
- Oil feed located at top of reservoir allows cleanest oil to enter pumping module.
- Infinitely adjustable, leak-tight gas ballast control and positive shut-off.
- Single phase, direct drive motor, totally enclosed, fan cooled with overload protection.
- Include two each one liter bottles of DirectTORR Gold Oil, two alumina oil filters, an oil mist exhaust filter that captures oil mist from the exhaust port and reduces pump noise to 50 dB, and a spanner wrench.

Catalog Number	Electrical Configuration	Displacement At 60 Hz (50 Hz) liters/minute	Dimensions w x d x h inches (cm)	Shipping Weight lbs. (kg)
7769600	110/120 volts, 50/60 Hz, 5.8 A Includes 115 volt NEMA 5-15P plug.	173 (144)	11.5 x 18.6 x 9.6 (29.0 x 47.2 x 24.3)	75 (34)
7769700*	200/220 volts, 50/60 Hz, 2.9 A Includes 220 volt NEMA 6-15 plug.	173 (144)	11.5 x 18.6 x 9.6 (29.0 x 47.2 x 24.3)	75 (34)
7769800	230 volts, 50/60 Hz, 2.9 A Includes 230 volt reverse IEC plug.	173 (144)	11.5 x 18.6 x 9.6 (29.0 x 47.2 x 24.3)	75 (34)

* Not for direct electrical connection to FreeZone Systems in this catalog.

Vacuum Pump Accessories

1988000 Vacuum Pump Oil. One liter bottle. For General Purpose Vacuum Pumps 1472100, 7739400, 7739402, 1467700, 7739401 and 7739403. Shipping weight 1 lb. (0.5 kg)

7772700 Replacement DirectTORR Gold Oil. One liter bottle. For General Purpose Pumps 7438700, 7438800, 7438900, 7439000, 7439100 and 7439200 (each uses one liter) and Chemical-Resistant Pumps 7769600, 7769700 and 7769800 (each uses two liters). Offers improved resistance to chemical attack. Highly saturated synthetic hydrocarbon oil resists breakdown at higher temperatures. Shipping weight 1 lb. (0.45 kg).

1472200 Inlet Filter. For General Purpose Vacuum Pumps 1472100, 7739400, 7739402, 1467700, 7739401 and 7739403. Prevents oil back streaming from the pump and protects the pump from damage from submicron particles. Includes filter assembly and one filter cartridge. Life approximately 1000 hours at 1.33×10^{-2} mBar (10 microns) vacuum. Shipping weight 1 lb. (0.5 kg)

1472500 Replacement Inlet Filter Cartridge. For 1472200. Shipping weight 0.5 lb. (0.2 kg)

1473400 Replacement Exhaust Filter. For General Purpose Vacuum Pumps 1472100, 7739400, 7739402, 1467700, 7739401 and 7739403. Removes oil mist and odor from pump exhaust. Ducting to outside not required. Includes filter assembly, one oil mist filter cartridge and one odor filter cartridge. Oil mist filter cartridge life is approximately one year and odor filter cartridge life is approximately six months at 1.33×10^{-2} mBar (10 microns) vacuum. Shipping weight 1 lb. (0.5 kg)

1473200 Replacement Oil Mist Exhaust Filter Cartridge. For 1473400. Life is approximately one year at 1.33×10^{-2} mBar (10 microns) vacuum. Shipping weight 0.5 lb. (0.2 kg)

1473300 Replacement Odor Exhaust Filter Cartridge. For 1473400. Life is approximately six months at 1.33×10^{-2} mBar (10 microns) vacuum. Package of five. Shipping weight 0.5 lb. (0.2 kg)

7438600 Replacement Oil Mist Exhaust Filter. For General Purpose Pumps 7438700, 7438800 and 7436900. Removes oil mist from the pump exhaust. Ducting to outside not required. Includes filter assembly and one oil mist filter cartridge. Life is approximately one year at 1.33×10^{-2} mBar (10 microns) vacuum. Shipping weight 1 lb. (0.5 kg)

7793800 Replacement Alumina Oil Filter. For Chemical-Resistant Pumps 7769600, 7769700 and 7769800. Neutralizes acid in the pump oil to help protect the pump. Shipping weight 1 lb. (0.5 kg)

7670400 Replacement Oil Mist Exhaust Filter. For General Purpose Pumps 7439000, 7439100 and 7439200 and Chemical-Resistant Pumps 7769600, 7769700 and 7769800. Removes oil mist from the pump exhaust. Ducting to outside not required. Includes filter assembly and one oil mist filter cartridge. Life is approximately one year at 1.33×10^{-2} mBar (10 microns) vacuum. Shipping weight 1 lb. (0.5 kg)



FreeZone® Benchtop Shell Freezers

SPECIFICATIONS & ORDERING INFORMATION

FreeZone Benchtop Shell Freezers provide a compact system for pre-freezing samples for lyophilization. The stainless steel bath has two rollers that rotate Fast-Freeze Flasks in a low temperature heat transfer solution, such as methanol or ethanol, so that a uniform thin coating of sample freezes to the interior surface of the container. Shell freezing increases the surface area to volume ratio, which facilitates efficient vapor flow from the sample to the collector during lyophilization.

All models feature:

- Brushed stainless steel and glacier white, epoxy-coated steel exterior with blue accents.
 - 1/3 hp CFC-free refrigeration system capable to cool the heat transfer solution to -40° C (-40° F).
 - Stainless steel bath, 5.5" w x 12.0" d x 6.5" h (14.0 cm x 30.5 cm x 16.5 cm), surrounded by urethane foam insulation with white high-density polyethylene cover. Two chain-driven rollers, powered by a sparkless induction motor, rotate flasks up to 1200 ml.
- Approximately two liters of transfer solution are required (not included).**
- LED temperature "wave" for at-a-glance display of bath temperature from -20 to -42° C. The highest LED illuminates amber when the main power switch is turned on. The second LED illuminates amber at approximately -20° C. The third LED illuminates amber at approximately -30° C. The fourth LED illuminates amber at approximately -35° C. The fifth LED illuminates amber at approximately -38° C. The sixth LED illuminates green at approximately -40° C. The bottom LED illuminates green at approximately -42° C.
 - Right-side mounted power switch.
 - Left-side mounted retractable bath drain hose.
 - 8-foot, 3-wire cord with plug.
 - Overall dimensions: 15.1" w x 22.1" d x 19.7" h (38.4 cm x 56.1 cm x 50.0 cm).

Models conform to the following standards:

- UL Standard 61010A-1 (115 and 230 volt, 60 Hz models).
- CAN/CSA C22.2 No. 1010.1 (115 and 230 volt, 60 Hz models).
- CE Conformity marking (230 volt, 50 Hz model).

Option includes:

- Domestic or international electrical configuration.



FreeZone Benchtop Shell Freezer 7949020.

Catalog Number	Electrical Requirements	Shipping Weight
7949020	115 volts, 60 Hz, 6.0 A	96 lbs. (44 kg)
7949040	230 volts, 60 Hz, 2.5 A	96 lbs. (44 kg)
7949030*	230 volts, 50 Hz, 2.5 A	96 lbs. (44 kg)

Fast-Freeze Flask Capacity of Benchtop Shell Freezer

Flask Size	Quantity
40 ml	2
80 ml	2
120 ml	2
150 ml	2
300 ml	1
600 ml	1
750 ml	1
900 ml	1
1200 ml	1

* International electrical configuration



Fast-Freeze® Flasks



Fast-Freeze Flasks

Select Fast-Freeze Flasks based on your sample sizes. Flasks should be filled to no more than one-third of their volume so that maximum surface area is achieved and efficient lyophilization is assured. A complete Fast-Freeze Flask includes a rubber top, glass bottom and a supply of filter paper. Tops, bottoms and filter paper are available separately as replacement components. Adapters are required to attach flasks to freeze dry valve ports.

Flask Size	Complete Flask	Flask Bottom	Flask Top	Flask Top Adapter Diameter*	Dimensions/Flask Bottom H x D
40 ml	7540000	7542000	7544000	1/2"	76 mm x 34 mm
80 ml	7540200	7542200	7544000	1/2"	115 mm x 34 mm
120 ml	7540300	7542300	7544200	3/4"	68 mm x 59.2 mm
150 ml	7540400	7542400	7544200	3/4"	85 mm x 59.2 mm
300 ml	7540600	7542600	7544200	3/4"	145 mm x 59.2 mm
600 ml	7540800	7542800	7544400	3/4"	135 mm x 90.2 mm
750 ml	7541100	7542700	7544400	3/4"	162 mm x 90.2 mm
900 ml	7540900	7542900	7544400	3/4"	190 mm x 90.2 mm
1200 ml	7541000	7543000	7544400	3/4"	240 mm x 90.2 mm
2000 ml	7541200	7543200	7544400	3/4"	380 mm x 90.2 mm



7422600 Tube Holder

Stainless steel. Accommodates up to 15 each 12 or 13 millimeter diameter tubes in an upright position inside a 750 ml or larger Fast-Freeze Flask or Lyph-Lock Flask (tubes and glassware are not included). 144 mm h x 83.3 mm diameter. Shipping weight 0.5 lb. (0.2 kg)



7422700 Tube Holder

Stainless steel. Accommodates up to 30 each 2.0 ml microcentrifuge tubes in an upright position inside a 750 ml or larger Fast-Freeze Flask or Lyph-Lock Flask (tubes and glassware are not included). 139 mm h x 83.3 mm diameter. Shipping weight 0.5 lb. (0.2 kg)

Variety of adapters available. You may select from glass or stainless steel adapters, available straight or with 45° bend. (Required — order separately.)

Top seals easily. The flexible silicone rubber top snaps on and off easily, yet provides a reliable, high vacuum seal.

Only two pieces per flask. The complete Fast-Freeze Flask has only two components:

- a high strength borosilicate glass bottom to withstand extreme temperatures and high vacuum.
- a flexible, non-contaminating silicone rubber top.

No vacuum grease is necessary.

No threads, hooks or springs are needed.

Entire flask may be autoclaved.

Compatible with all major brands of laboratory freeze dry apparatus.

No complex filter retainer is necessary. For those who use filters, they are easily inserted between the adapter and top of the flask. One hundred filters are supplied with each flask.

Wide mouth opening loads fast, cleans easily.

Horizontal shell freezing. Flask may be placed in a horizontal position and rotated in a bath for shell freezing.

Available in ten convenient sizes.

Flat bottom reduces spills, provides better balance.

Adapters

Add the Adapters for connecting the Fast-Freeze Flasks to the valve ports on your drying chamber or manifold. Choose borosilicate glass or stainless steel adapters in 1/2" and 3/4" diameters.

Diameter	Straight Adapter	45° Bend Adapter
Borosilicate Glass		
1/2" flask top to 1/2" valve*	7545000	7545600
3/4" flask top to 3/4" valve*	7545200	7545800
1/2" flask top to 3/4" valve*	7545400	7546000
3/4" flask top to 1/2" valve*	7545400	7546000
Stainless Steel		
1/2" flask top to 1/2" valve*	7547000	7547400
3/4" flask top to 3/4" valve*	7547200	7547600

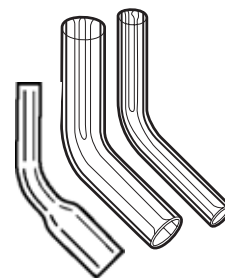
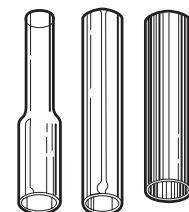

7544810 Replacement Filter Paper

1000 (10 packages of 100). 1" diameter (28mm). Pore size 17 microns. Shipping weight 0.5 lb. (0.2 kg)

*Valves on the freeze dry systems, drying chambers and manifolds offered in this catalog fit adapters of both 1/2" and 3/4" sizes. Size information is provided for selecting adapters for older Labconco models and other freeze dryers.



Lyph-Lock® Flasks



Lyph-Lock Flasks

Select the Lyph-Lock Flasks based on your sample sizes. Flasks should be filled to no more than one-third of their volume so that maximum surface area is achieved and efficient lyophilization is ensured. A complete Lyph-Lock Flask includes a glass top and bottom and a rubber ring seal. Tops, bottoms and seals are available separately as replacement components. Adapters are required to attach flasks to freeze dry valve ports.

Flask Size	Complete Flask 19/38 STJ	Complete Flask 24/40 STJ	Flask Top 19/38 STJ	Flask Top 20/40 STJ	Lyph-Lock Seal	Flask Bottom	Dimensions Flask Bottom H x ID
25 ml	7550000	7554000	7552000	7556000	7559000	7557000	37 mm x 34 mm
50 ml	7550200	7554200	7552000	7556000	7559000	7557200	67 mm x 34 mm
100 ml	7550400	7554400	7552200	7556200	7559200	7557400	50 mm x 59.2 mm
250 ml	7550600	7554600	7552200	7556200	7559200	7557600	110 mm x 59.2 mm
500 ml	7550800	7554800	7552400	7556400	7559400	7557800	103 mm x 90.2 mm
750 ml	7550900	7554900	7552400	7556400	7559400	7557900	145 mm x 90.2 mm
1000 ml	7551000	7555000	7552400	7556400	7559400	7558000	187 mm x 90.2 mm



7442600 Tube Holder

Stainless steel. Accommodates up to 15 each 12 or 13 millimeter diameter tubes in an upright position inside a 750 ml or larger Fast-Freeze Flask or Lyph-Lock Flask (tubes and glassware are not included). 144 mm h x 83.3 mm diameter. Shipping weight 0.5 lb. (0.2 kg)



7442700 Tube Holder

Stainless steel. Accommodates up to 30 each 2.0 ml microcentrifuge tubes in an upright position inside a 750 ml or larger Fast-Freeze Flask or Lyph-Lock Flask (tubes and glassware are not included). 139 mm h x 83.3 mm diameter. Shipping weight 0.5 lb. (0.2 kg)

Borosilicate glass adapters with either 19/38 or 24/40 standard taper joints have 90° bend. (Required — order separately.)

Compatible with all major brands of laboratory freeze dry apparatus.

Only three pieces per flask — no hooks or springs. The complete Lyph-Lock Flask includes:

- a flask top of high strength borosilicate glass
- a flexible, non-contaminating silicone rubber seal
- a flask bottom of borosilicate glass to withstand extreme temperatures and high vacuum.

Silicone rubber seal grasps top and bottom. The flexible ring holds securely together during pre-freezing and lyophilization.

LABCONCO

Available in seven convenient sizes.

Entire flask may be autoclaved.

Provides a high vacuum seal for efficient lyophilization.

Flat bottom reduces spills, provides better balance.

Adapters

Add the Adapters for connecting the Lyph-Lock Flasks to the valve ports on your drying chamber or manifold.

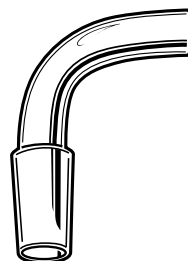

90° Bend Adapter	Description
7568000	Connects 19/38 STJ Flask Top to 1/2" valve*
7568200	Connects 19/38 STJ Flask Top to 3/4" valve*
7568400	Connects 24/40 STJ Flask Top to 1/2" valve*
7568600	Connects 24/40 STJ Flask Top to 3/4" valve*

*Valves on the freeze dry systems, drying chambers and manifolds offered in this catalog fit adapters of both 1/2" and 3/4" sizes. Size information is provided for selecting adapters for older Labconco models and other freeze dryers.



Serum Bottles & Vials



Serum Bottles

Perfect for long term storage of freeze dried samples. Labconco Serum Bottles and Threaded Vials are specifically designed for lyophilization applications. Their uniform thin wall construction ensures even freezing and drying. Bottles and vials are ideal containers for use in the FreeZone Stopping Tray Dryer. Serum bottles also connect to valve ports on drying chambers and manifolds. Serum Bottles, Stoppers and Seals are supplied in packages of 100.

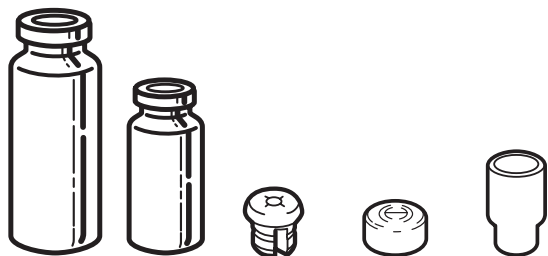

Size	20 mm Corkage	13 mm Corkage	Split Stoppers	Aluminum Seals	Sleeve-Type Stoppers
2 ml		7575010	7576010	7577010	
3 ml		7575210	7576010	7577010	
5 ml	7573010		7576210	7577110	7577510
10 ml	7573210		7576210	7577110	7577510
20 ml	7573410		7576210	7577110	7577510
30 ml	7573610		7576210	7577110	7577510
50 ml	7573810		7576210	7577110	7577510
100 ml	7574010		7576210	7577110	7577510
125 ml	7574210		7576210	7577110	7577510

Threaded Vials

Stoppers and Threaded Vials with Screw Caps are supplied in packages of 200.

Size	Vials with Screw Caps	Stoppers
5 ml	7762300	7762200
10 ml	7762600	7762200

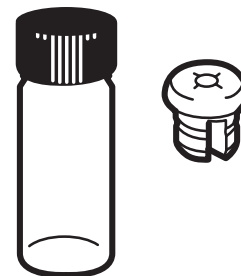

Accessories



Seal Crimpers

Secure tear-away Aluminum Seals.

7578000 Seal Crimper. For 13 mm corkage. Shipping weight 3 lbs. (1.4 kg)

7578100 Seal Crimper. For 20 mm corkage. Shipping weight 3 lbs. (1.4 kg)

7593000 Vacuum Stopping Adapter. Connects to a valve port for manual stopping of a 20 mm corkage serum bottle under original vacuum. The stopper and serum bottle are inserted into the adapter body and lyophilization begins. After the process is completed, the researcher slides the stopper into position so when the valve is turned from vacuum to vent the serum bottle is tightly sealed by the stopper. The ejector tube is then used to force the serum bottle out of the adapter. Shipping weight 1 lb. (0.4 kg)

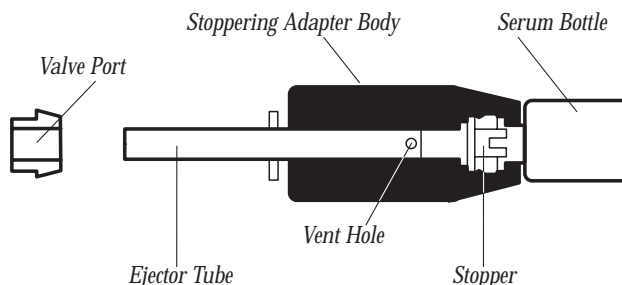



Ampules & Miscellaneous Accessories

Ampules

Labconco Ampules are fabricated of highest quality borosilicate glass for strength and durability. Ampules are supplied in packages of 100.

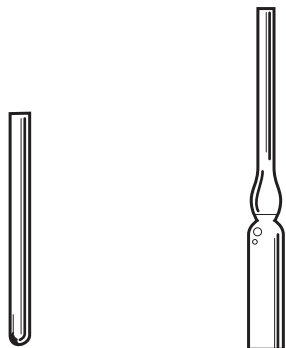

Size	Straight	Pre-Scored Flat Bottom
1 ml	7572710	7570610
2 ml		7570810
5 ml		7571010
10 ml		7571210



7578500 Oxygen/Natural Gas Sealing Torch. Specifically designed for flame sealing freeze dry ampules. Seals all types of heat-resistant glass. Connects to natural gas, butane or propane and oxygen with 1/4" ID hose connectors. Shipping weight 3 lbs. (1.4 kg)



7593401 Ampule Valve Adapters. Connect ampules to valve ports or stainless steel stems. Ten per package. Shipping weight 0.5 lb. (0.2 kg)

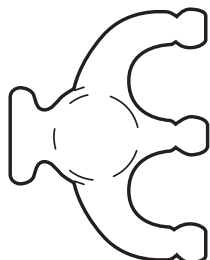

7762700 Three Way Adapter. Permits attachment of three ampules to a single valve port. Ampules are attached using Ampule Valve Adapters or 1/8" surgical tubing (not provided). Cavity in adapter body can be filled with cotton fiber media to help prevent contamination between samples. Shipping weight 3 oz. (0.1 kg)



7439300 Microcentrifuge Tube Holder. 3.0" w x 2.25" d x 1.0" h (7.6 cm x 5.7 cm x 2.5 cm), anodized aluminum block with twelve bore holes that accommodate 1.7 ml microcentrifuge tubes. Holder may be placed on any flat freeze drying surface such as inside Clear Chambers, Heated Drying Chambers, or the built-in vacuum drying chamber of FreeZone Console Systems; or on FreeZone Stopping or Bulk Tray Dryer Shelves, Product Shelves, or Heated Product Shelves. One each. **Microcentrifuge tubes are not included.** Shipping weight 0.6 lb. (0.3 kg)



Digital Electronic Vacuum Gauges Provide a LCD display of vacuum measurement in mBar, PA or Torr. Range is 0.02 mBar to 5 mBar. Stainless steel and glacier white epoxy-coated steel casing, 8.1" w x 4.1" d x 6.4" h. Include a cord with 3/8" to 1/2" OD adapter for connection to either vacuum tubing or a valve on a drying chamber. All FreeZone Freeze Dry Systems include a digital vacuum gauge. The Dry Ice Benchtop Freeze Dry System or other freeze dryers may use the Digital Electronic Vacuum Gauge as an accessory.

Catalog Number	Electrical Requirements	Shipping Weight
7395000	115 volts, 60 Hz, 0.4 A	10 lbs. (4.5 kg)
7395001*	230 volts, 50 Hz, 0.2 A	10 lbs. (4.5 kg)



Glass Lids Replace the acrylic lids included with FreeZone Freeze Dry Systems and Drying Chambers. Provide additional protection from solvents and corrosives that attack acrylic, such as acetonitrile. Glass with neoprene gasket.

Catalog Number	For Use With:	Diameter	Shipping Weight
7439903	FreeZone 4.5 Liter Systems	10.12"	2.5 lbs. (1.1 kg)
7439902	FreeZone 6, 12 & 18 Liter Systems 16-Port Drying Chamber	14.00"	3.5 lbs. (1.6 kg)
7439900	12-Port Drying Chamber	9.25"	2.0 lbs. (0.9 kg)



Miscellaneous Accessories

RS-232 Cables

Provide connection from the RS-232 port on any FreeZone 2.5, 4.5, 6, 12 or 18 Liter Freeze Dry System or FreeZone Bulk Tray Dryer to an IBM-compatible, user-supplied computer. An RS-232 Cable may also be connected to the RS-232 port on the FreeZone Stopping Tray Dryer connected to a computer; however, the Interconnect Cable 7353403 included with the Stopping Tray Dryer is recommended since it allows the Stopping Tray Dryer to communicate with the Freeze Dry System. See page 30 for more information.

Catalog Number	RS-232 Cable	Shipping Weight
7537800	For connection to computer with 9-pin serial data port	0.5 lb. (0.2 kg)
7537801	For connection to computer with 25-pin serial data port	0.5 lb. (0.2 kg)



7426400 Support Shelves

Attach easily without tools to the sides of the FreeZone 1, 2.5 or 4.5 Liter Freeze Dry System or left-hand side of the FreeZone Triad System cabinet to provide support for large flasks attached to the drying chamber or manifold. Multiple rows of perforations on the sides of the FreeZone

cabinet allow for height adjustment of the shelves to support various sizes of flasks. One pair. Glacier white epoxy-coated steel. Each shelf is 7.4" w x 12.0" d (18.7 cm x 30.5 cm). Shipping weight 2 lbs. (0.9 kg)

7814300 Bleed Valve

Bleeds vacuum when all valves are in use on the Dry Ice Freeze Dry System. 1/2" OD connections. Shipping weight 0.5 lb. (0.3 kg)



7579000 Rubber Tubing Clamp

Clamp completely seals heavy wall vacuum tubing up to 3/4" ID for use in leak detection. Shipping weight 5 lbs. (2.3 kg)

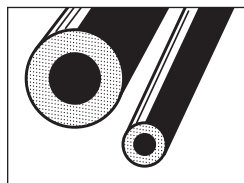

7645900 Replacement Neoprene Tubing

For Dry Ice Benchtop Freeze Dry System connections, 5/16" ID x 3/16" wall, 3' length. Shipping weight 5 lbs. (2.3 kg)

7646000 Neoprene Tubing

For connection of vacuum pump to the Freeze Dry System, 3/4" ID x 3/8" wall, 3' length. Shipping weight 5 lbs. (2.3 kg)



7509600 Replacement Valve

For drying chambers and manifolds manufactured after March, 1996. Consists of neoprene body and gaskets, molded plastic knob and fittings. Accommodates both 1/2" and 3/4" adapters. Shipping weight 1 lb. (0.4 kg)



8025000 Portable Table

May be used to support FreeZone 1, 2.5 or 4.5 Liter Benchtop Freeze Dry System on the top shelf while supporting a Rotary Vane Vacuum Pump on the lower shelf. Glacier white epoxy-coated tubular steel.

4" diameter casters, two with toe locks. Extruded rubber

handle grips. Supports loads up to 400 pounds. Lifetime guarantee. Dimensions: 34.9" x 19.0" x 36.4" h. (37.4 cm x 48.3 cm x 92.5 cm). Shipping weight 44 lbs. (20 kg)



8075000 Variable Height Bench

May be used to support a FreeZone 6 Liter Benchtop Freeze Dry System with any drying accessory except the Stopping Tray Dryer mounted on top. Glacier white epoxy-coated tubular steel. Phenolic board with melamine high-pressure

laminated surface. Height is adjustable from 29.6 to 37.4" (75.1 to 94.9 cm) using steel pins with nuts inserted in vertical frame members. 5" diameter, non-marking, toe-locking casters with bearings. Supports loads up to 540 pounds. Lifetime guarantee. Work surface dimensions: 38.0" x 28.0" x 1.1" thick (96.5 cm x 71.1 cm x 2.8 cm). Shipping weight 111 lbs. (50 kg)



Contact Labconco for more information about these quality products for your laboratory.



HEPA-Filtered Biological Safety Cabinets, Enclosures & Clean Benches



Fume Hoods & Carbon-Filtered Enclosures



Balance Enclosures



Laboratory Animal Research Stations



Glove Boxes



Glassware Washers



Water Purification Systems



Centrifugal Connectors & Cold Traps



Multiple Sample Evaporation Systems



Agricultural Chemistry Products



Laboratory Carts & Benches



Blood Drawing Chairs



Digital Chloridimeters



Vacuum Desiccator



Density Gradient Fractionators



Protecting your laboratory environment

LABCONCO

Labconco Corporation

8811 Prospect Avenue
Kansas City, Missouri 64132-2696
816-333-8811 or 800-821-5525
FAX 816-363-0130
labconco@labconco.com
www.labconco.com

