

Class 150 Ductile Iron Body Gate Valves

Raised face flanges • bolted bonnet • outside screw and yoke • solid wedge • bronze trim

285 PSI/19.7 bar non-shock cold working pressure to -20°F to 100°F/-29°C to 38°C*

Maximum working temperature 650°F/343°C at 125 PSI/8.6 bar

150 PSI/10.3 bar saturated steam to 366°F/186°C

CONFORMS TO MSS SP-128

MATERIAL LIST

PART	SPECIFICATION
1. Stem	Brass ASTM B 371
2. Handwheel Nut	Brass ASTM B584
3. Identification Plate	Aluminum
4. Yoke Bushing	Brass ASTM B584 C84400
5. Handwheel	Iron ASTM A126 Class B
6. Bonnet Cap Nut	Steel ASTM A563
7. Bonnet Cap	Ductile Iron ASTM A536
8. ¹ Bonnet	Ductile Iron ASTM A395
9. Bonnet Cap Bolt	Steel ASTM A307/SAE J429
10. Gland Follower Nut	Steel ASTM A563
11. Gland Follower	Ductile Iron ASTM A536
12. Packing Gland	Zinc Plated Powdered Iron ASTM B783 or Brass ASTM B16 Alloy C3600
13. Packing	PTFE Braided Synthetic Fiber
14. Gland Follower Bolt	Steel ASTM A307/SAE J429
15. Backseat Bushing	Brass ASTM B584 C84400
16. Body Nut	Steel ASTM A563
17. Body Bolt	Steel ASTM A307/SAE J429
18. Wedge Pin	Brass ASTM B 371 C69430/C69400
19. Body	Ductile Iron ASTM A395
20. ³ Seat Ring	Bronze ASTM B584 C84400
21. Wedge Face Ring	Brass ASTM B584 C84400
22. ² Wedge	Ductile Iron ASTM A395
23. Body Gasket	Synthetic Fibers
24. Stem Collar	Brass ASTM B 371 C69430/C69400
25. Grease Fitting	Alemite 1743B (not shown)

¹Sizes thru 8" made with Yoke Integral with Bonnet. 10" and 12" sizes made with separate Yoke Bolted to Bonnet.

²Sizes 2" thru 6" are all Bronze (31 Trim).

Sizes 8" thru 12" Ductile Iron Wedge with Bronze Wedge Face Rings (31 Trim).

³Lugs may be removed at customer's request - POA.

DIMENSIONS—WEIGHTS—QUANTITIES

Size	Dimensions										Weight		
	A		B		C		D		E		Lbs.	Kg.	
In.	mm.	In.	mm.	In.	mm.	In.	mm.	In.	mm.	In.	mm.		
2	50	7.00	178	16.31	414	8.00	203	6.00	152	.63	16	41	19
2½	65	7.50	191	17.19	437	8.00	203	7.00	178	.69	17	55	25
3	80	8.00	203	19.50	495	8.00	203	7.50	191	.75	19	67	30
4	100	9.00	229	24.00	610	10.00	254	9.00	229	.94	24	107	48
5	125	10.00	254	27.13	689	10.00	254	10.00	254	.94	24	145	66
6	150	10.50	267	31.06	789	12.00	305	11.00	279	1.00	25	178	81
8	200	11.50	292	40.19	1021	14.00	356	13.50	343	1.13	29	309	140
10	250	13.00	330	48.25	1226	16.00	406	16.00	406	1.19	30	481	218
12	300	14.00	356	56.88	1445	18.00	457	19.00	483	1.25	32	706	320



F-637-31
Flanged-Raised Face

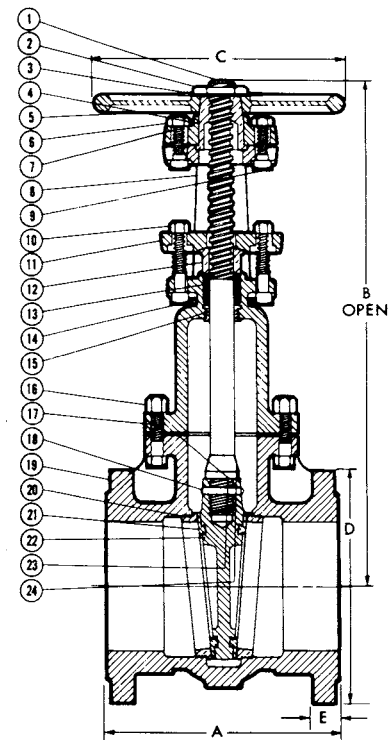

F-637-31
Flg x Flg

FREEZING WEATHER PRECAUTION: Subsequent to testing a piping system, valves should be left in an open position to allow complete drainage.

◆For detailed Operating Pressure, refer to Pressure Temperature Chart on page 114.

VISIT WWW.NIBCO.COM FOR CURRENT CHEM-GUIDE AND GALVANIC POTENTIAL IN PIPING SYSTEMS INFORMATION.

Visit our website for the most current information.