

BEIJING HUADE HYDRAULIC INDUSTRIAL GROUP CO.,LTD.	2/2-, 3/2- and 4/2-way poppet directional valves, solenoid actuated Type M-.SEW 6			RE 22058/12.2004
	Size 6	up to 42/63 MPa	up to 25 L/min	Replaces; RE22058/05.2001

Features:

- Direct actuated directional poppet valve, solenoid actuated
- Closed port is leak-free
- Switching is ensured even after long periods of being under pressure
- Solenoid coil can be rotated by 90°
- Individual electrical connection
- With protected hand override, optional
- Porting pattern to Din 24 340 form A, ISO 4401 and CETOP-RP 121H



Type
M-3SEW6U30B/420MG24N9K4
with plug-in connector

Function,section

General:

The 2 type M-.SEW directional valve is a solenoid actuated directional poppet valve. They control the start, stop and direction of a flow. They basically consist of a housing (1), the solenoids (2), the hardened valve system (3) and the ball(s) (4) as the closing element.

Basic principle:

In the initial position the ball (4) is pressed onto the seat by the spring (9), and in the switched position by the solenoid (2). The solenoid (2) force acts via the lever (6) and the ball (7) on the actuator pin (8), which is sealed on two sides. The chamber between the two sealing elements is connected with port P. The valve system (3) is thereby pressure balanced with regard to the actuating forces (solenoid or return spring). The valves can, therefore, be used up to a pressure of 63 MPa.

Note:

The 3/2-way poppet valves have a "negative switching overlap". Therefore, port T must always be connected. This means that during the switching procedure from the start of opening one valve seat to the closing of the other seat - all of the ports P-A-T are connected with each other. This, however, takes place in such a short space of time that in most applications it is irrelevant.

The hand override (10) makes it possible to switch the valve without energizing the solenoids.

Care has to be taken to ensure that the stated maximum flows are not exceeded! If necessary a cartridge throttle for flow limitation has to be fitted (see below).

The following possibilities are obtainable via the seat orientation:

	2/2-way poppet valve	3/2-way poppet valve
Symbol	"P" 	"U"
Initial position	P and T connected	P and A connected, T closed leak-free
Switched position	P closed leak-free	P closed leak-free, A and T connected
Symbol	"N" 	"C"
Initial position	P closed leak-free	P closed leak-free, A and T connected
Switched position	P and T connected	P and A connected, T closed leak-free

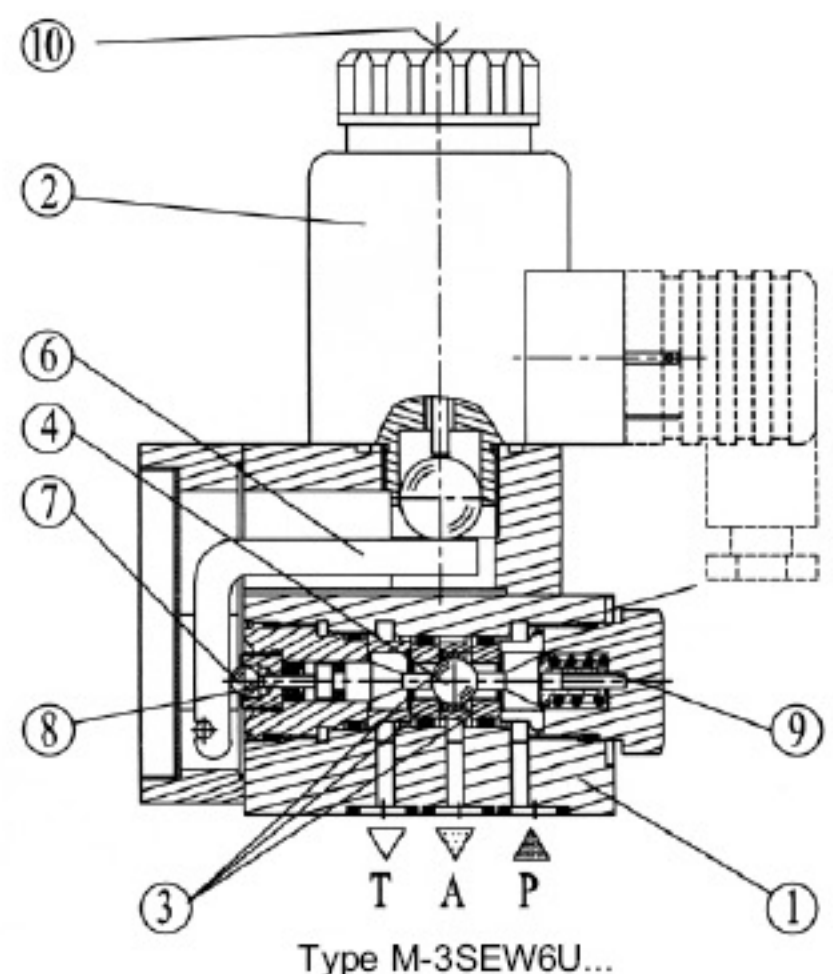
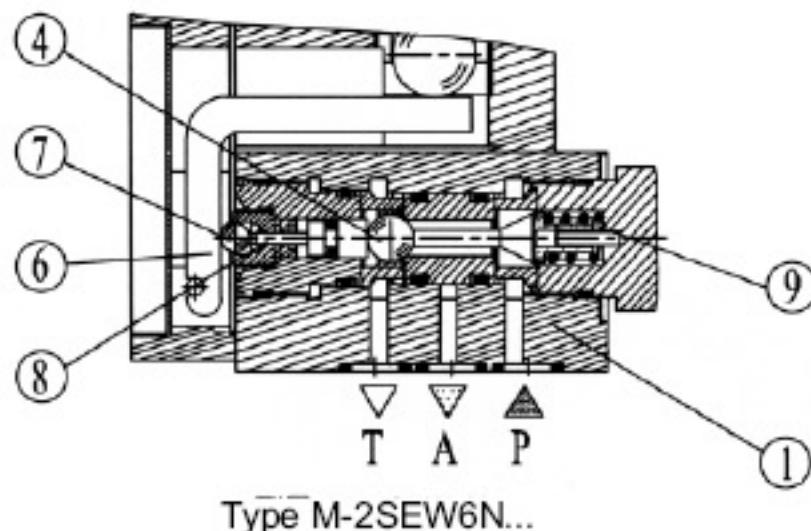

Illustration: 4/2-way poppet valve

In conjunction with a sandwich plate, a plus-1 plate, under the 3/2-way poppet valve this valve can be used as 4/2-way poppet valve.

Function of the plus-1 plate:

Initial position:

The main valve is not actuated. The spring (9) holds the ball (4.1) on the seat (11). Port P is closed and A is connected to T. In addition, a control line runs from A to the large area of the control spool (12), which is thus unloaded to tank. The pressure applied via P now moves the ball (13) onto seat (14). Thus, P is connected to B and A to T.

Transition position:

When the main valve is operated, the ball (4.2) is pushed against the spring (9) and then pressed onto the seat (15). Port T is then blocked, P, A and B are connected to each other for a short time.

Switched position:

P is connected to A. As the pump pressure acts via A on the large area of the control spool (12), ball (13) is pushed onto seat (16). Thus, B is connected to T and P to A. Ball (13) in the plus-1 plate has a "positive switching overlap".

In order to avoid pressure intensification when single rod cylinders are used, the annulus area of the cylinder must be connected to A.

Schematic illustration: initial position

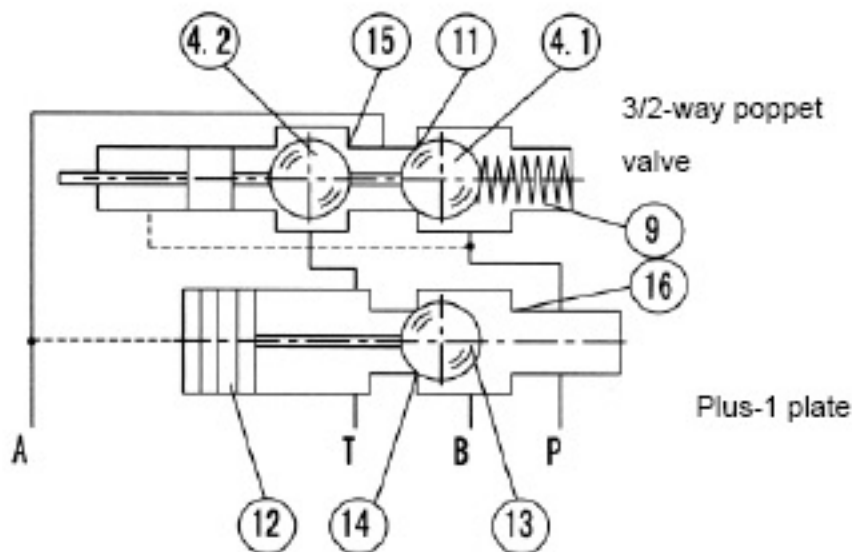

Due to the use of the plus-1 plate and the arrangement of the seats, the following combinations are possible:

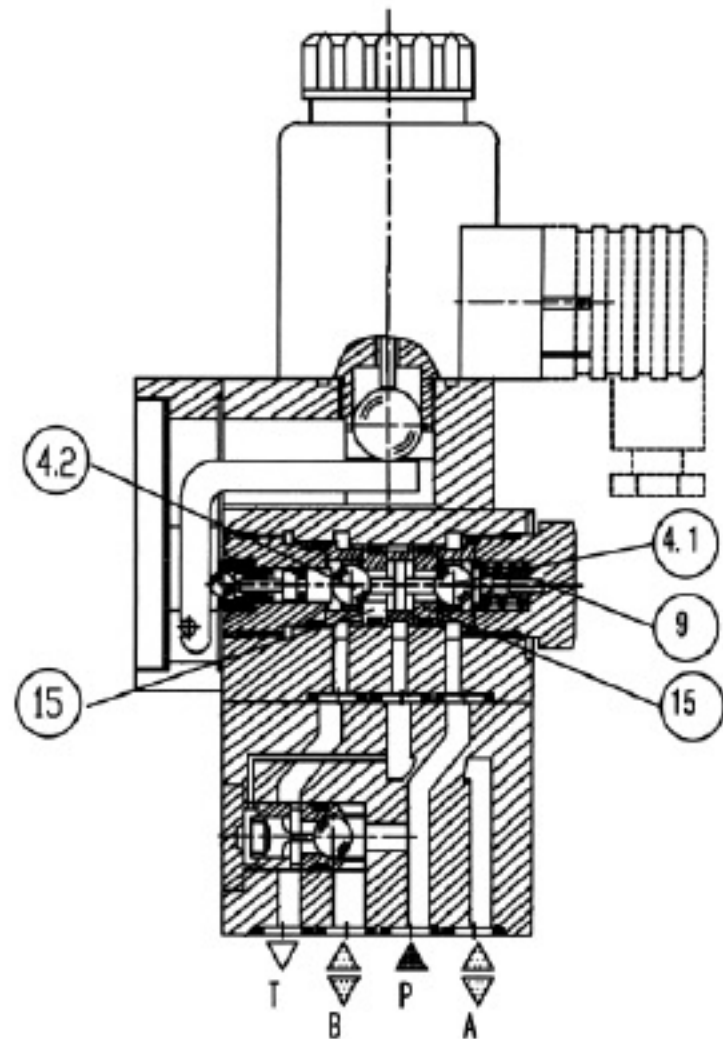
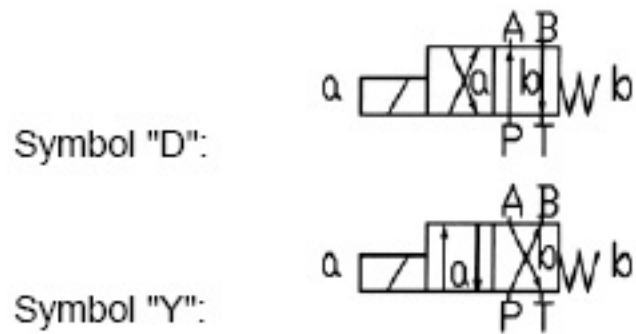

Type M-4SEW6Y...

Cartridge throttle

The use of the cartridge throttle is necessary when, due to operational conditions during the switching process, flows can occur that exceed the valve performance limits.

Example:

- Accumulator operation,
- Use as a pilot valve with internal pilot oil supply.

3/2-way poppet valve

The cartridge throttle is fitted into port P of the poppet valve.

4/2-way poppet valve (see next page)

The cartridge throttle is fitted into port P of the plus-1 plate.

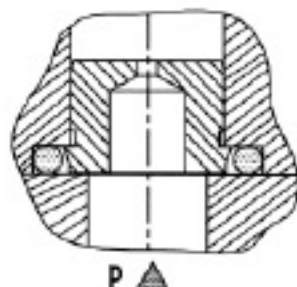

Cartridge check valve

The cartridge check valve allows free flow from P to A and provides leak-free closure from A to P.

For examples, see page 11.

3/2-way poppet valve

The cartridge check valve is

inserted into port P of the poppet valve. 4/2-way poppet valve (see next page)

The cartridge check valve is

inserted into port P of the plus-1 plate.

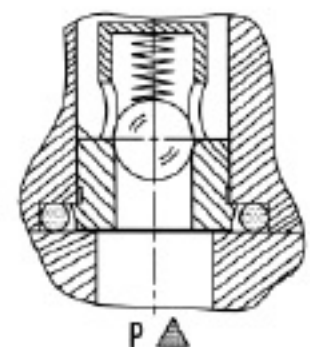

Ordering details

M - SEW 6 30 B / M *

2 service ports =2
3 service ports =3
4 service ports =4

Nominal size 6 = 6

Service ports	2	3	4	
	•	-	-	=P
	•	-	-	=N
	•	•	-	=U
	•	•	-	=C
	-	-	•	=D
	-	-	•	=Y

• = Available

Series 30 to 39 = 30
(30 to 39: unchanged installation and connection dimensions)

Technology of Beijing Huade Hydraulic =B

Operating pressure up to 42 MPa (fixing screws M5) = 420
Operating pressure up to 63 MPa (fixing screws M6) = 630

AC supply (permissible voltage tolerance $\pm 10\%$)	Nominal voltage of the DC solenoid when used with an AC voltage	Order detail
110V-50/60Hz	96V	G96
120V-60Hz		
230V-50/60Hz	205V	G205

Further details
in clear text

No code = mineral oils
V = phosphate ester

No code = Without cartridge check valve,
without throttle insert
P = With cartridge check valve
B12 = Throttle ϕ 1.2 mm
B15 = Throttle ϕ 1.5 mm
B18 = Throttle ϕ 1.8 mm
B20 = Throttle ϕ 2.0 mm
B22 = Throttle ϕ 2.2 mm

Electrical connection
K4¹⁾ = Individual connection
without plug, with protection cover

N9 = With protected manual override
No Code = Without manual override

G24 = 24VDC
G205²⁾ = 205VDC

M = Solenoid (air gap) with removable coil

Note: Other types of actuators e.g.pneumatic,hydraulic,
rotary knob,rotary knob with lock,plunger,lever,roller
lever) on request!

1) Plug-in connectors have to be ordered separately (see below).
2) For the connection to an AC supply a DC solenoid must be used
which is controlled via a rectifier (see table on the left).
For individual connections a large plug-in connector with integrated
rectifier can be used (separate order, see below).

Ordering details: plug-in connector

Plug-in connections
DIN 43 650
ISO 4400

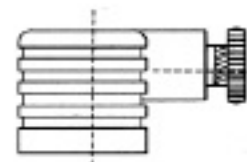

large-size connector

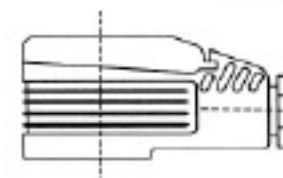

		Without indicator light	With indicator light	Without rectifier	With indicator light and Z-diode protective circuit
a grey	Material no.	008 616	313 923/24V 313 926/180-240V	313 932	310 994

Performance limits (measured at $v = 41 \text{ mm}^2 / \text{s}$ and $t = 50 \text{ }^\circ\text{C}$)

	Symbol	Comments	Operating pressure in MPa				Flow L/min
			P	A	B	T	
2-way circuit	"P"	Pressure to $P \geq T$	42/63			10	25
	"N"		42/63			10	25
3-way circuit	"U"	Pressure to $P \geq A \geq T$	42/63	42/63		10	25
	"C"		42/63	42/63		10	25
2-way circuit (only for unloading function)	"U"	Before switching from the initial position to the switched position, pressure must be present in port A. Pressure at $A \geq T$		42/63		10	25
	"C"	Pressure at $A \geq T$		42/63		10	25
4-way circuit	"D"	Single ball valve (symbol "U") in conjunction with a plus-1 plate $P \geq A \geq B \geq T$	42/63	42/63	42/63	10	25
	"Y"	Two ball valve (symbol "C") in conjunction with a plus-1 plate $P \geq A \geq B \geq T$	42/63	42/63	42/63	10	25

General guidelines

- In order to operate the valve safely and to hold it safely in the switched position, the pressure in P must be $\geq A \geq T$ (for design reasons).
- The ports P, A and T (3/2-way poppet valve) as well as P, A, B and T (4/2-way poppet valve) are positively assigned to their individual functions. They must not be interchanged or plugged. Flow is only permitted in the direction of the arrow.
- When using the plus-1 plate (4/2-way function) the following lower operating values must be taken into account: $p_{min} = 0.8 \text{ MPa}$; $q_v > 3 \text{ L/min}$.
- The specified maximum flow must not be exceeded.

The performance limit was determined with the solenoids at operating temperature, 10% under voltage and with the tank not pressurized.

Recommended type (Could Supplied in short time)

Ordering Type:

- M-3SEW6 C 30/ 420 MG24 N9 K4
- M-3SEW6 C 30/ 630 MG24 N9 K4
- M-3SEW6 U 30/ 420 MG24 N9 K4
- M-3SEW6 U 30/ 630 MG24 N9 K4

Technical data (For applications outside these parameters, please consult us!)

General		
Installation		optional
Max. ambient temperature	(°C)	50
Weight	2/2-way poppet valve (kg)	1.5
	3/2-way poppet valve (kg)	1.5
	4/2-way poppet valve (kg)	2.3
Hydraulic data		
Max. operating pressure	(MPa)	see table on page 140
Max. flow	(L/min)	25
Pressure fluid		mineral oils or phosphate ester
Pressure fluid temperature range	(°C)	- 30 to + 80
Viscosity range	(mm ² /s)	2.8 to 500
Degree of contamination	µm	Maximum permissible degree of contamination of the hydraulic fluid to NAS 1638 class 9. We therefore recommend a filter with a minimum retention rate of $\beta_{10} \geq 75$.
Electrical data		
Type of voltage		DC AC
Available voltages ¹⁾	(V)	12, 24, 42, 96, 110, 205, 220 only possible via rectifier
Voltage tolerance (nominal voltage)	(%)	± 10
Power consumption	(W)	30
Duty		100%
Switching time to ISO 6403		see table below
Switching frequency	(cycle s/h)	15000
Protection to DIN 40 050		IP65
Max. coil temperature	(°C)	to 150

1) Special voltages on request

When connecting the electrics, the protective conductor (PE \perp) must be connected according to the relevant regulations.

Switching time in ms (installation: solenoid vertical)																		
Pressure in MPa	Flow q_v in L/min	DC solenoid						DC solenoid + rectifier										
		Symbols U, C, D, Y						Symbols U, C, D, Y										
		t_{on}				t_{off}		t_{on}				t_{off}						
		Without tank pressure						Without tank pressure										
		U	C	D	Y	C	Y	U	C	D	Y	C	Y					
14	25	25	30	25	30	10	10	30	40	30	40	35	35					
28								35	45	35	45	40	40					
32								40	35	50	40	50	50	55	40	55	50	50
42									50								50	
50									55								55	
60									55								55	

Characteristic curves (measured at $v = 41 \text{ mm}^2/\text{s}$ and $t = 50^\circ\text{C}$)

$\Delta p - q_v$ -characteristic curves
2/2-way poppet valve

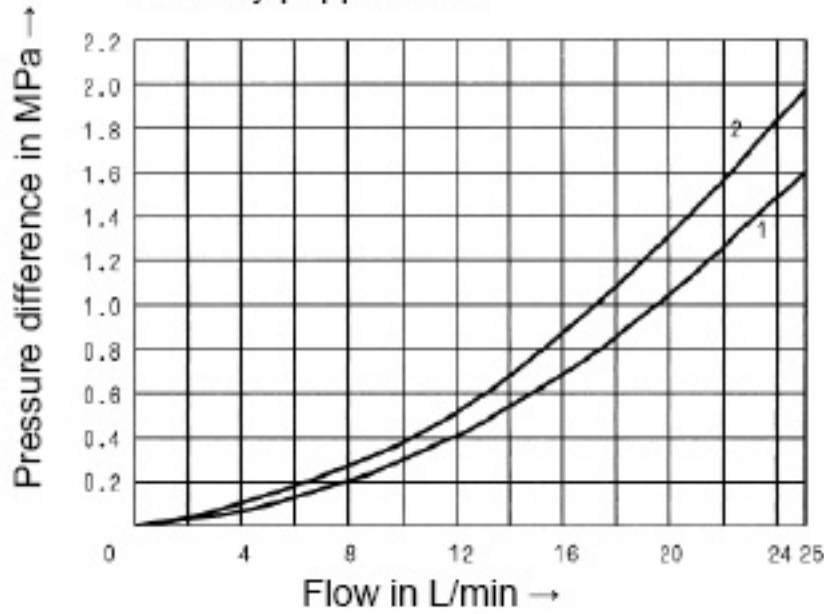

- 1 M-2SEW 6 N ... P to T
- 2 M-2SEW 6 P ... P to T

$\Delta p - q_v$ -characteristic curves
4/2-way poppet valve

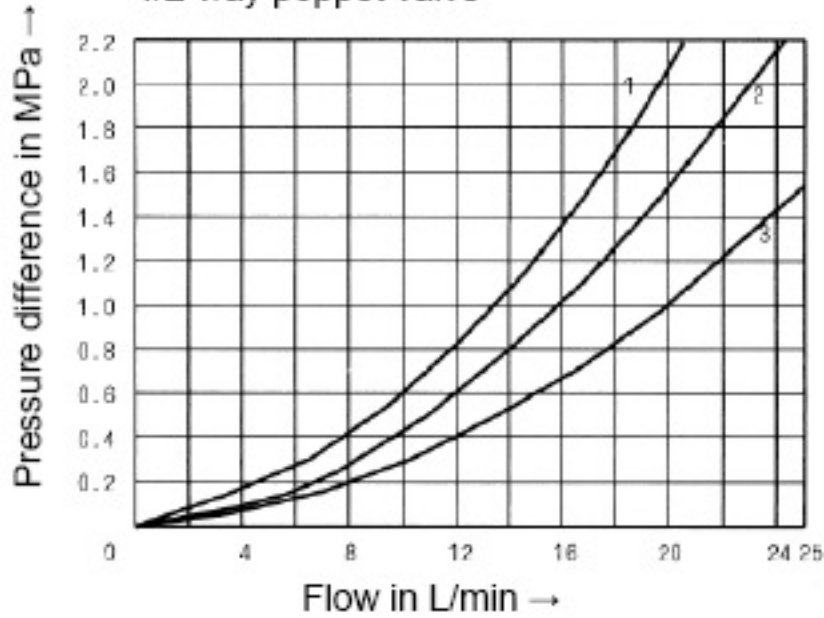

$\Delta p - q_v$ -characteristic curves
3/2-way poppet valve

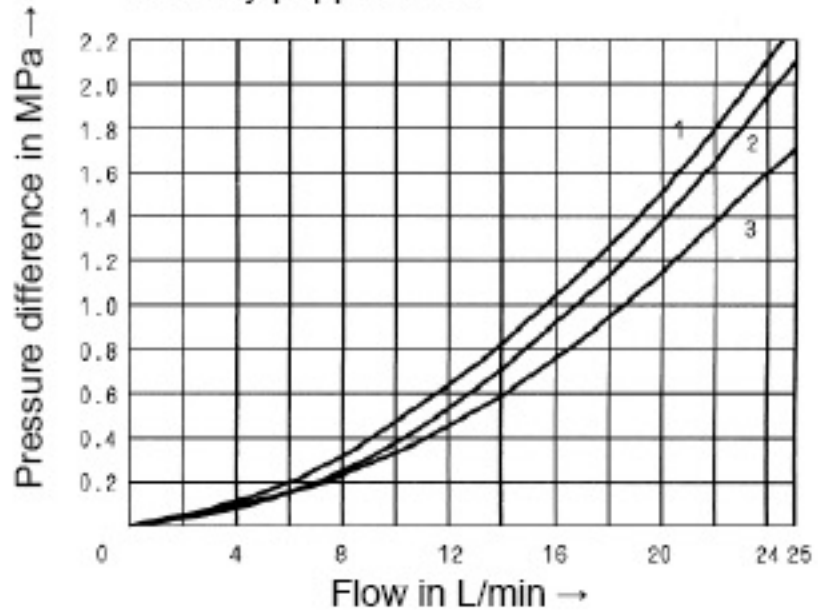

- 1 M-3SEW 6 $\begin{smallmatrix} U \\ C \end{smallmatrix}$..., A to T
- 2 M-3SEW 6 U... P to A
- 3 M-3SEW 6 C ... P to A

- 1 M-4SEW 6 $\begin{smallmatrix} D \\ Y \end{smallmatrix}$..., A to T

- 2 M-4SEW 6 $\begin{smallmatrix} D \\ Y \end{smallmatrix}$..., P to A

- 3 M-4SEW 6 $\begin{smallmatrix} D \\ Y \end{smallmatrix}$..., P to B, B to T

$\Delta p - q_v$ -characteristic curve
Cartridge check valve

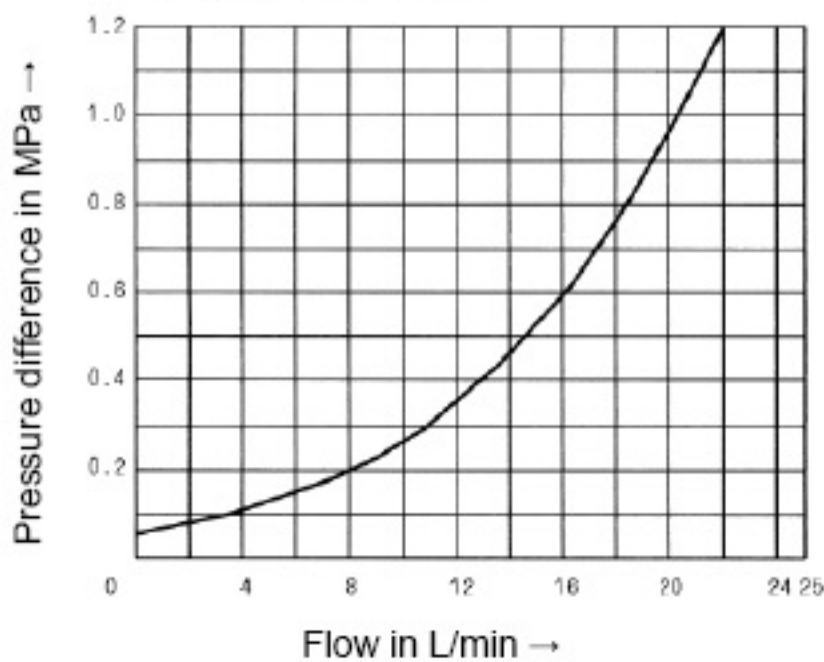

$\Delta p - q_v$ -characteristic curves
Throttle insert

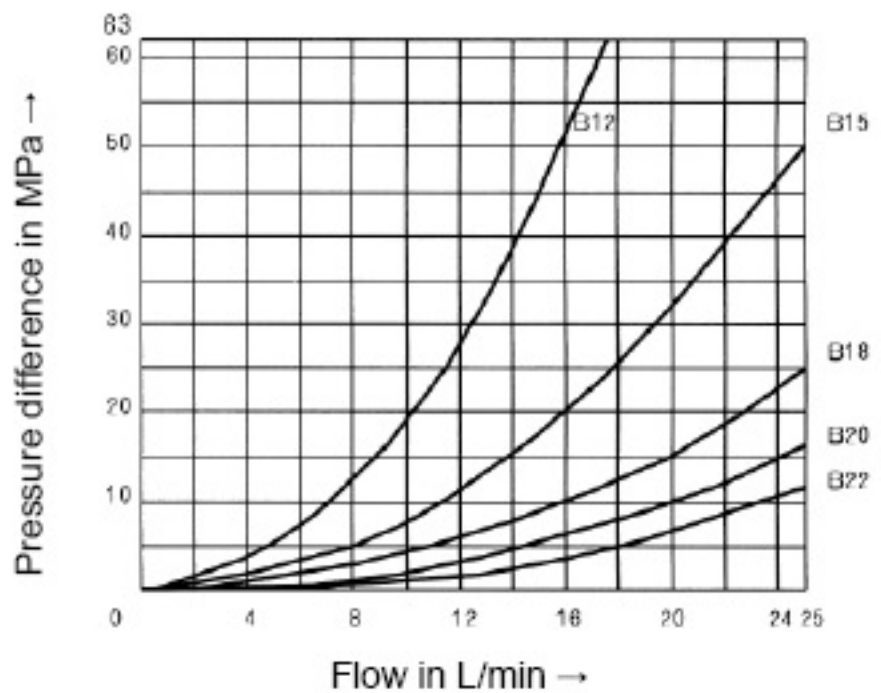

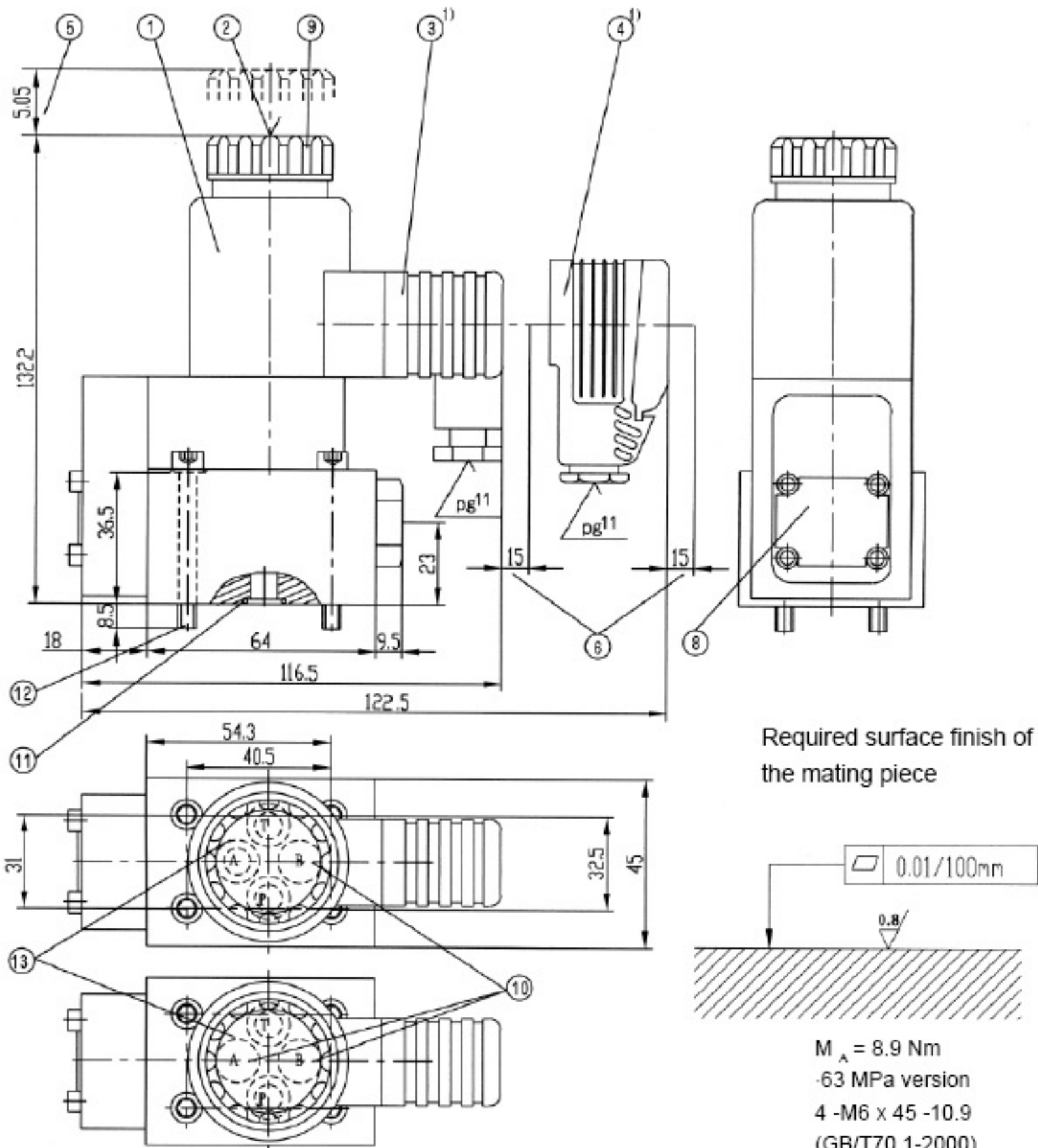

Required surface finish of the mating piece

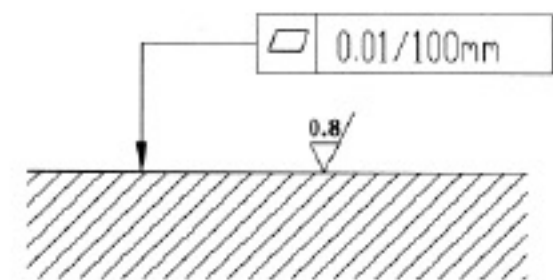

- 1 Solenoid "a" (plug-in connector colour grey)
- 2 Protected hand override "N9"
- 3 Plug-in connector to DIN 43 650 ¹⁾ (may be rotated by 90°)
- 4 Large plug-in connector to DIN 43650 ¹⁾ (may be rotated by 90°)
- 5 Space required to remove the coil
- 6 Space required to remove the plug-in connector
- 8 Nameplate
- 9 Fixing nut, tightening torque $M_A = 4 \text{ Nm}$
- 1) Must be ordered separately, see page 141.

- 10 Attention!
On 3/2-way poppet valves (42 MPa version), port B is a blind counter bore.
On 2/2-way poppet valves (42 MPa version) ports A and B are blind counter bores.
- 11 O-rings 9.25 x 1.78 for ports A, B and T
O-ring 10.82 x 1.78 for port P
- 12 Valve fixing screws
-42 MPa version
4 - M5 x 45 -10.9 (GB/T70.1-2000)

- $M_A = 8.9 \text{ Nm}$
-63 MPa version
4 -M6 x 45 -10.9 (GB/T70.1-2000)
 $M_A = 15.5 \text{ Nm}$
are included within the scope of supply.
- 13 Porting pattern to DIN 24 340 form A, ISO 4401 and CETOP-RP 121 H

Subplates:(see page 205)
42 MPa version
G341/01(G1/4")
G342/01(G3/8")
G502/01(G1/2")
63 MPa version
G576/01(G1/4")
G577/01(G3/8")
must be ordered separately.

Unit dimensions: 4/2-way poppet valve

(Dimensions in mm)

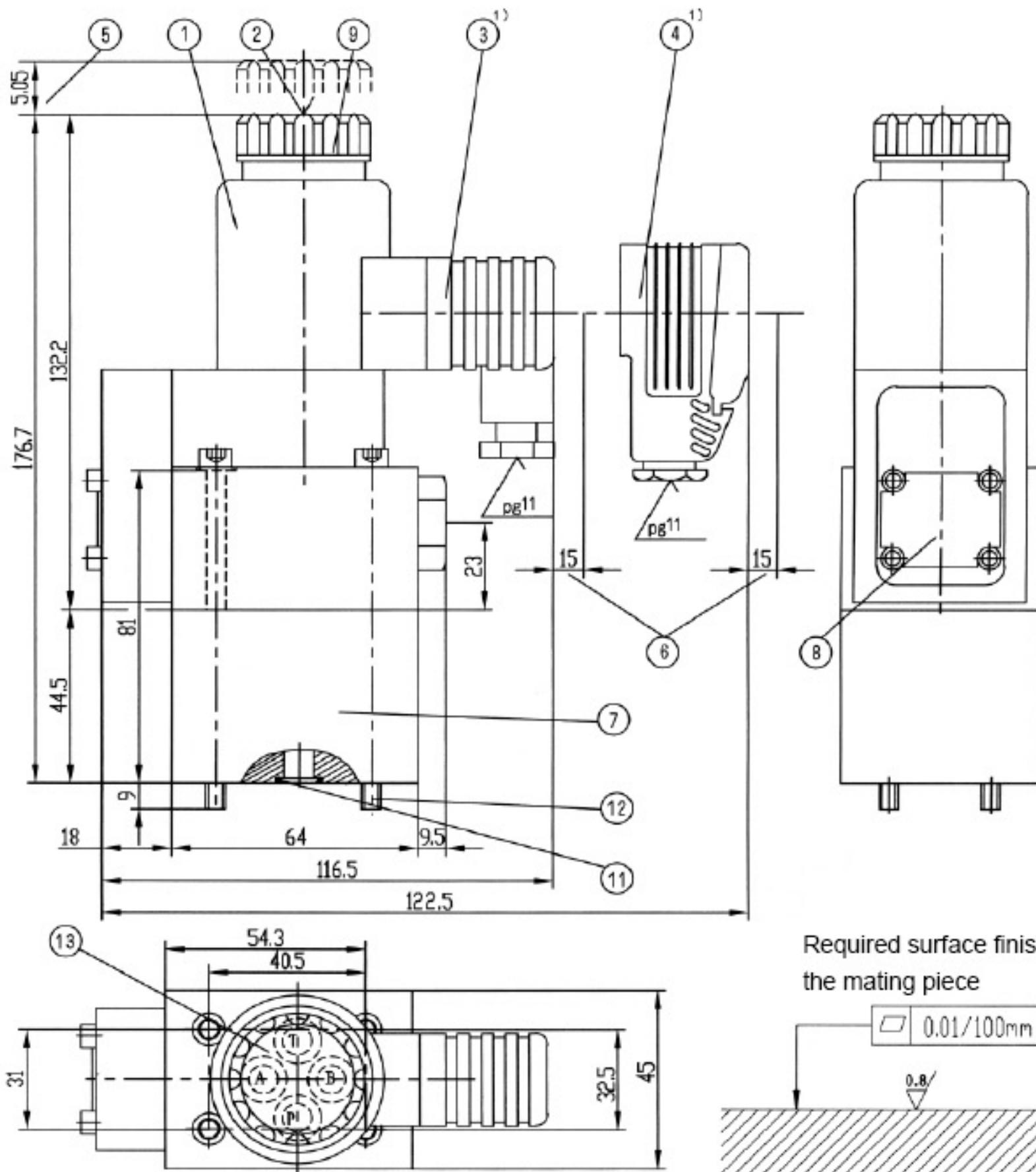

- 1 Solenoid "a" (plug-in connector colour grey)
- 2 Protected hand override "N9"
- 3 Plug-in connector to DIN 43 650 1) (may be rotated by 90°)
- 4 Large plug-in connector to DIN 43650 1) (may be rotated by 90°)
- 5 Space required to remove the coil
- 6 Space required to remove the plug-in connector
- 7 Plus-1 plate
- 8 Name plate
- 9 Fixing nut, tightening torque

- 11 O-rings 9.25x 1.78 for ports A, B and T
O-ring 10.82 x 1.78 for port P
- 12 Valve fixing screws
 - 42 MPa version
4 -M5 x 90 -10.9 (GB/T70.1-2000), $M_A = 8.9 \text{ Nm}$
 - 63 MPa version
4 -M6 x 90 -10.9 (GB/T70.1-2000), $M_A = 15.5 \text{ Nm}$

Required surface finish of the mating piece

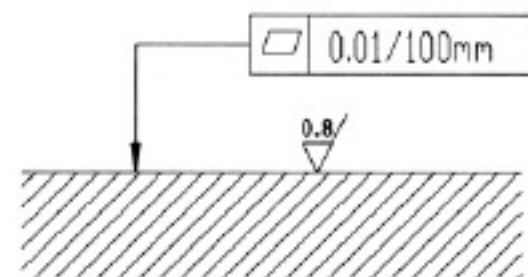

are included within the scope of supply.

- 13 Porting pattern to DIN 24 340 form A, ISO 4401 and CETOP-RP 121 H
Subplates (see page 205)
 - 42 MPa version
G341/01(G1/4")
G342/01(G3/8")
G502/01(G1/2")
 - 63 MPa version
G576/01(G1/4")
G577/01(G3/8")
 must be ordered separately.

1) must be ordered separately, see page 141

Application examples

These examples serve only to explain the possibilities offered by the poppet valve. They do not include the complete function.

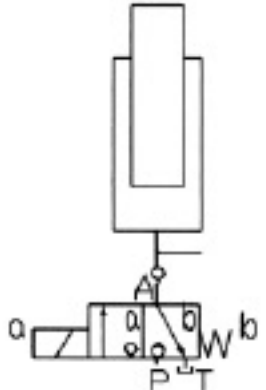
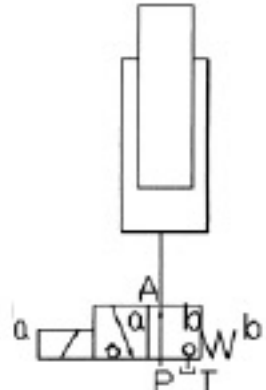
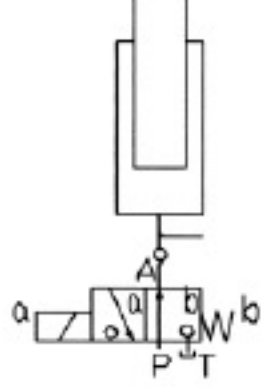
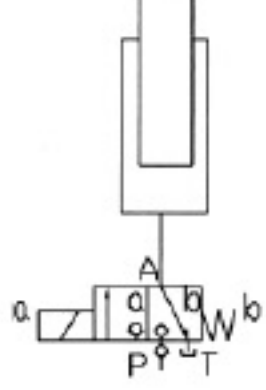
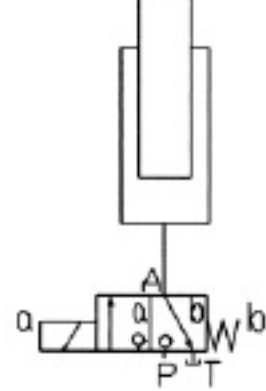
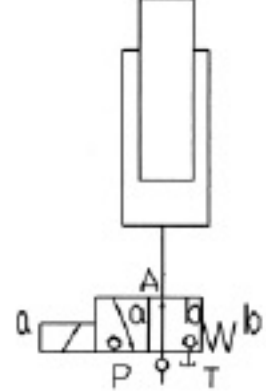
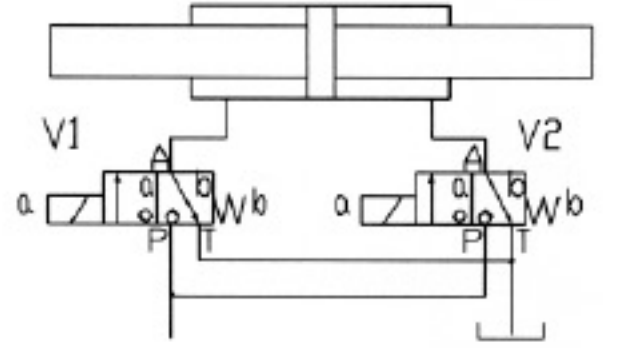
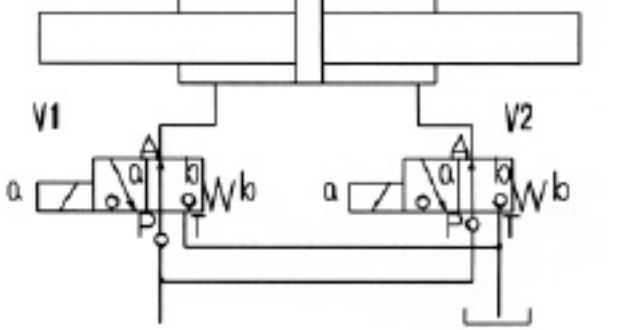
<p>Symbol "C"</p> 	<p>2/2-way circuit with a two poppet valve and check valve at port A</p> <p>The check valve must be installed in the pipe work.</p> <p>Initial position: Flow blocked, maximum pressure permissible. Pressure is held in the actuator, even when the pump is switched off, due to the check valve at port A.</p> <p>Switched position: Free-flow, maximum pressure permissible. Leakage drained via port T. The only leakage occurring is that which flows to T during the switching process.</p>	<p>Symbol "C"</p> 	<p>3/2-way circuit with a single poppet valve</p> <p>Initial position: Lifting</p> <p>Holding only due to limitation of travel and pressure in port P.</p> <p>Switched position: Lowering</p>
<p>Symbol "U"</p> 	<p>2/2-way circuit with a single poppet valve and check valve at port A</p> <p>The check valve must be fitted in the pipe work.</p> <p>Initial position: Free-flow, maximum pressure permissible. Pressure is held in the actuator, even when the pump is switched off, due to the check valve at port A.</p> <p>Switched position: Flow blocked, maximum pressure permissible. Leakage drained via port T. The only leakage occurring is that which flows to T during the switching process.</p>	<p>Symbol "C"</p> 	<p>3/2-way circuit with a two poppet valve and cartridge check valve in port P</p> <p>The check valve is fitted in the P port of the 3/2-way poppet valve.</p> <p>Initial position: Lowering</p> <p>Switched position: Lifting</p> <p>The load can be held in any position while the pump is switched off and the solenoid energized.</p>
<p>Symbol "C"</p> 	<p>3/2-way circuit with a two poppet valve</p> <p>Initial position: Lowering</p> <p>Switched position: Lifting</p> <p>Holding only due to limitation of travel and pressure in port P.</p>	<p>Symbol "U"</p> 	<p>3/2-way circuit with a single poppet valve and cartridge check valve in port P</p> <p>The check valve is fitted into the P port of the 3/2-way poppet valve.</p> <p>Initial position: Lifting</p> <p>The load can be held in any position while the pump is switched off.</p> <p>Switched position: Lowering</p>
<p>Symbol "C"</p> 	<p>4/3- (4/4-) way circuit with a 2 two poppet valves</p> <p>V1 and V2 in the initial position: Both cylinder sides are connected to the tank port.</p> <p>V2 in the switched position: The piston moves to the left</p> <p>V1 in the switched position: The piston moves to the right</p> <p>V1 and V2 in the switched position: Both cylinders sides are connected to the pump port.</p> <p>Rapid traverse is possible when a single rod cylinder with an area ratio of 2 : 1, is used.</p> <p>Attention!</p> <p>When using single rod cylinders, the performance limit (double flow) and the maximum permissible operating pressure (pressure intensification) of the valve must be taken into account.</p>		
<p>Symbol "U"</p> 	<p>4/3- (4/4-) way circuit with a 2 two poppet valves and cartridge check valve in port P of the 3/2-way poppet valves</p> <p>V1 and V2 in the initial position: The piston is locked externally to prevent movement.</p> <p>V2 in the switched position: The piston moves to the right</p> <p>V1 in the switched position: The piston moves to the left</p> <p>V1 and V2 in the switched position: Both cylinder sides are connected to the tank port.</p> <p>Attention!</p> <p>When using single rod cylinders, the performance limit (double flow) and the maximum permissible operating pressure (pressure intensification) of the valve must be taken into account!</p>		

Notice

1. The fluid must be filtered. Minimum filter fineness is 20 μm .
2. The tank must be sealing up and an air filter must be installed on air entrance.
3. Products without subplate when leaving factory, if need them, please ordering specially.
4. Valve fixing screws must be high intensity level (class 10.9). Please select and use them according to the parameter listed in the sample book.
5. Roughness of surface linked with the valve is required to $\frac{0.8}{\sqrt{\text{R}}}$.
6. Surface finish of mating piece is required to 0.01/100mm.